

THE CATALOGUE

karboxx

LIGHT,
MORE
LIGHT.



REACTIV · OFFICE DESIGN



Ch J-Ph de Sauvage 37 Bât. "Verntissa" 1219 Châtelaine · GENEVE
SWITZERLAND · TEL: +41 (0)22 797 05 12 · WWW.ROD-DESIGN.CH

Ch J-Ph de Sauvage 37
Bâtiment "Verntissa"
1219 Châtelaine (GE)
Tel: +41 (0)22 797 05 12

Karboxx continua il lavoro di ricerca e di approfondimento delle tematiche progettuali da sempre alla base della filosofia di crescita dell'azienda.

Osservare le persone ed i loro modi di vivere.

Scoprire ed anticipare le tendenze ed abilità nell'interpretare concetti esistenti creando combinazioni originali, stabilendo nuovi valori.

Ecco le collezioni di raffinata semplicità che da sempre caratterizzano e contraddistinguono Karboxx.

Karboxx continues its research and in-depth analysis of the design themes that have always been at the basis of the company's growth culture. Observing people and lifestyles. Discovering and anticipating trends and ability to interpret existing concepts, creating unorthodox combinations and thereby setting new standards. New collections always in line with the image of sophisticated simplicity that has been a recurring and distinctive feature of Karboxx.

Karboxx setzt seine Anstrengungen in Forschung und Untersuchung der Design-Themen fort, die seit jeher im Mittelpunkt der Wachstumsphilosophie sind: Menschen und ihre Lebensweise beachten, Trends und Fähigkeiten entdecken und vorhersehen und bestehende Konzepte in originelle Kombinationen und neue Werte umsetzen. Hier sind die Kollektionen, von eleganter Schlichtheit geprägt, die Karboxx unterscheiden.

Karboxx poursuit son travail de recherche et d'analyse en profondeur des thèmes du design qui sont depuis toujours à l'origine du développement de la Société. Observer les gens et leur style de vie. Découvrir et anticiper les tendances avec la capacité d'interpréter les concepts existant, créer des mélanges peu orthodoxes et les transformer en nouveaux standards. Nouvelle collection toujours en adéquation avec l'image de simplicité sophistiquée qui a toujours été le signe distinctif de Karboxx.



ENRICO FRANZOLINI
Nato a Udine nel 1952 studia a Firenze e Venezia dove si laurea in Architettura. Nel 1972 fu invitato a partecipare alla 36^a Biennale di Venezia esponendo oggetti in vetro di Murano prodotti dal laboratorio di Livio Seguso. Nel 1978 la sua prima personale alla Galleria Plurima di Udine, inizio di un lavoro di ricerca nell'architettura minimale

continuando il suo impegno nel disegno industriale.

Born in Udine in 1952. He studied in Florence and graduated in architecture at the University of Venice. In 1972 he was invited to the 36th Biennale Exhibition of decorative arts in Venice, exhibiting two objects produced by the Livio Seguso glass-manufactory in Murano. In 1978 his first personal exhibi-

tion at Plurima Gallery in Udine marked the beginning of his interest in minimal architecture. At the same time however he became interested in architecture and interior and product design.



SERENA PAPAÏT
Serena Papait, nasce a Portogruaro (Venezia) nel 1985. Si diploma nel 2007 in Disegno Industriale all'Università di Venezia ed inizia fin da subito a collaborare con numerose aziende e professionisti. Forte è la passione per l'arte e la fotografia come l'amore per la luce e le sue forme.

Serena Papait was born in Portogruaro (Venice) in 1985, where she achieved the teacher-training diploma and began to grow her art passion, taking part in some collective exhibition of the territory. She enrolled in the course of Industrial Design at the University Institute of Architecture in Venice IUAV dove si diploma nel 2007.



VICENTE GARCÍA JIMENEZ
Nato a Valencia (Spagna) nel 1978. Diplomato in Ingegneria Tecnica in Disegno Industriale all'Univeristà Castellon de la Plana trasferendosi poi a Barcellona. Parallelamente sviluppa i suoi interessi nell'ambito del design realizzando e sperimentando prototipi. Si trasferisce a Udine dove apre il suo studio che sviluppa

prodotti di illuminazione, mobili ed allestimenti collaborando con numerose aziende.

Vicente was born in Valencia (Spain) in 1978. He graduated at the Faculty of Experimental Sciences in Castellon de la Plana. Later he moved to Barcelona. There he developed lighting and interior furniture designs. At this time he developed an interest with the environmental

aspect of designing these items, constructing his first prototypes in this field. He moved towards Udine and he set up his Studio, that collaborates with a lot of companies, developing lighting products, furniture and exhibitions' settings.



FABIO FLORA
Cerca oggetti che rappresentano le forme archetipali, funzionali e costruttive. Cerca di conoscere la genesi. Analizza i modelli simbolici ed i valori di progettazione composti da semplici elementi geometrici.

He Looks for objects that represent archetype forms, functional and constructive. He tries to know the genesis. He analyses the symbolic values designing models made up from simple geometrical elements.



DAVID DOLCINI
"Credo che l'anima di ciò che chiamiamo design risieda nel costante rapporto tra complessità e semplicità, tra ciò che è visibile e ciò che è celato. Da sempre ho subito il fascino degli oggetti che incarnano questo delicato e raffinato gioco di equilibri. In ogni mio prodotto cerco di ricreare questa magia". Nato in Italia, nei pressi di Milano. La sua visione e il suo approccio al progetto provengono dalla mescolanza di molteplici esperienze educative e di lavoro all'estero nel corso degli anni.

"My work aim to investigate the relationship between complexity and simplicity, in search of that magic that only the delicate play of balances between these two elements can recreate". David was born in Italy, near Milan. His vision and approach to design comes from a whole variety of educational and professional experiences abroad over a number of years.



THOMAS FEICHTNER
Il lavoro di Thomas Feichtner si concentra sugli aspetti artistici e della sperimentazione. Cercando una modalità progettuale che non rispetta il dogma tradizionale e che va oltre la globalizzazione e la produzione di massa. Il suo lavoro coniuga sia l'aspetto artistico oltre alla sperimentazione. I suoi lavori sono presenti nelle più importanti collezioni nel mondo. È professore

alla Muthesius Academy of Fine Arts and Design ed ha ricevuto il riconoscimento dalla Austrian State Award for Design nell'anno 2011. Abita e vive a Vienna.

Thomas Feichtner work is focused on artistic aspects and a more experimental approach. In search of an independent mode of operation that went beyond globalization and mass production. His works have been

acquired by the most important design collections all over the world. Feichtner is a professor for product design at the Muthesius Academy of Fine Arts and Design and was awarded by the Austrian State Award for Design 2011. He lives and works in Vienna.



BRIAN RASMUSSEN
Nato a Ringsted (Danimarca) nel 1973. Si laurea alla Royal Accademy di Architettura a Copenhagen nel 2000. Il suo progetto futuristico per una stazione metro, vince il premio "PRISOPGAVE KØBENHAVN" (Danimarca). Dopo gli studi si trasferisce a Venezia, aprendo il suo studio di architettura e design. Nel 2004, vince il premio

internazionale, Targetti Light Art Ward, che segna l'inizio della sua carriera quale light designer.

Brian was born in Ringsted (Denmark) in 1973. He graduates at The Royal Academy of Architecture in Copenhagen in 2000. All ready as a first year student his wins the national student competition " PRISOPGAVE KØBENHAVN" (Denmark) with

a project for a futuristic metro station. After his studies he moved to Venice, opening his own office of architecture and design. In 2004 he wins the international art competition Targetti Light Art Ward which becomes a starting point for his career as lighting designer.



MARTA LAUDANI E MARCO ROMANELLI
Marta Laudani e Marco Romanelli, architetti, collaborano dal 1988 negli studi associati di Roma e Milano. Operativi nei campi del design, dell'architettura degli interni, dell'exhibit design (si ricorda, nel 2002-2003 l'antologica "Gio Ponti: a World" al Design Museum di Londra e alla Triennale di Milano; nel 2007 "Bruno Munari" al Tokyo Shio-dome Italia). Il lavoro di progetta-

zione si è sempre affiancato per entrambi ad un'intensa riflessione critica sui temi dell'abitare e del design: Marta Laudani ha insegnato "Architettura degli interni" e "Storia del design contemporaneo" alla facoltà di Architettura della Sapienza di Roma.

Marta Laudani and Marco Romanelli, architects, have been collaborating since 1988 in the associated offices of Rome and Milan.

They work in the fields of design, interior decorating and exhibit design (in 2002-2003 "Gio Ponti: a World" at the London Design Museum, Rotterdam Nal and Triennial of Milan; in 2007 "Bruno Munari" in Tokyo). Both flank their design work with an intense critical meditation on topics involving living and design: Marta Laudani has lectured at the Sapienza in Rome. lighting products, furniture and exhibitions' settings.



MASSIMILIANO MORNATI
Como 1970, si laurea in architettura a Milano nel 1998, dopo esperienze in studi di architettura a Rotterdam, Berlino e Milano inizia la sua attività di progettista nei campi dell'architettura, dell'allestimento e del disegno del prodotto. continuando il suo impegno nel disegno industriale.

Como 1970, graduated in Architecture in Milan 1998, after gaining experience in architects' studios in Rotterdam, Berlin and Milan he began his activity as an industrial designer.



MORENO DE GIORGIO
Dopo la Laurea in Architettura a Venezia apre lo studio nel 2006 e si concentra sugli aspetti peculiari del disegno per l'industria. Alterna attività di ricerca a fare "artigiano", forte radicamento al territorio di appartenenza a tematiche di respiro globale, come sostenibilità, efficienza, paesaggio. Con la rivoluzione Led si appassiona al lighting e a illuminare in maniera efficace e confortevole residenza, luoghi di lavoro, spazi per il commercio, spazi espositivi, che considera veri e propri "habitat" per le persone.

After he graduated in Architecture in Venice he opened his own studio in 2006, directly involved as external consultant in a number of corporate teams. With the Led revolution, he focuses on lighting for workspaces the he considers as real "habitat" for the people.

TERRA
FLOOR
LAMPADAIRE
STEHLEUCHTE

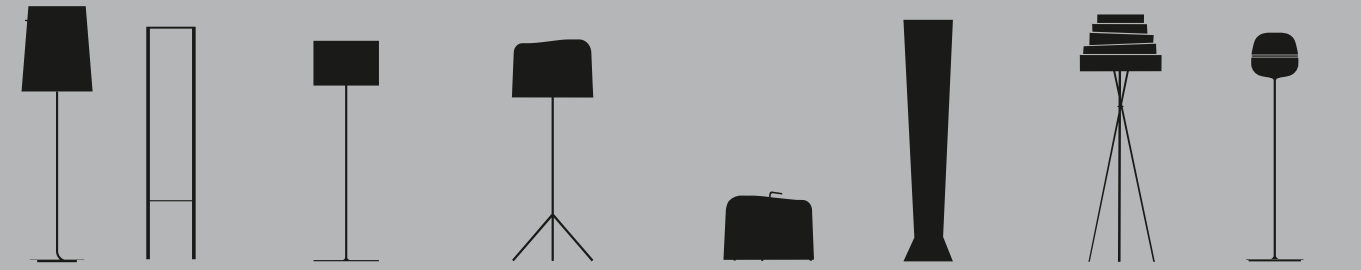

GRACE P 14 OPPO P 50 HALF MOON P 56 OLA P 70
OLA MOVE P 74 ELIOS P 98 BABEL P 106 AFRA P 116

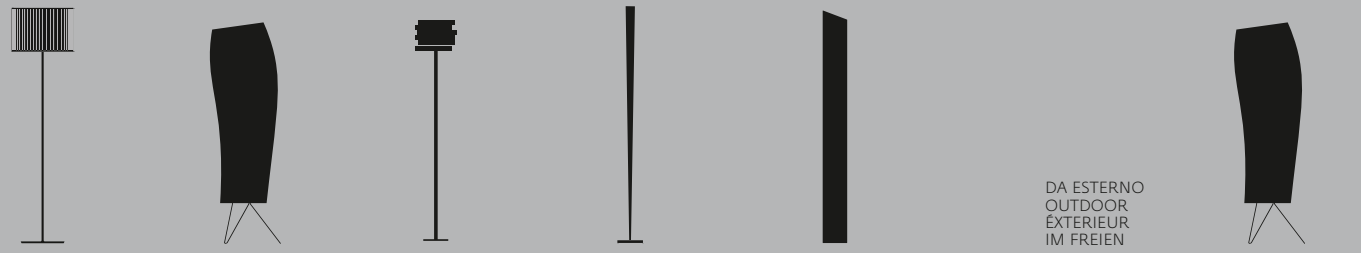

PEGGY P 130 WARM P 132 ESCAPE P 138 DRINK P 214 SLICE P 238 WARM P 132

DA ESTERNO
OUTDOOR
EXTERIEUR
IM FREIEN

TAVOLO
TABLE
TISCHLEUCHTE



GRACE P 18 GRACE P 18 HALF MOON P 60 HALF MOON MINI P 64 OLA P 78 OLA P 82

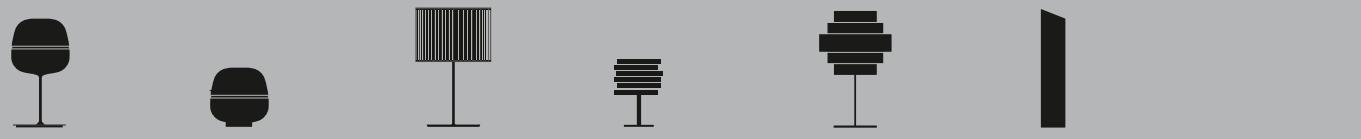

AFRA P 120 AFRA P 120 PEGGY P 126 ESCAPE P 142 SUN P 208 SLICE P 234

SOFFITTO
CEILING
PLAFONNIER
DECKENLEUCHTE



OLA SLIM P 94 DRINK P 212 DRINK BICOONO P 218 SLICE P 230 TUBE P 244

SOSPENSIONE
SUSPENDED
SUSPENSION
PENDELLEUCHTE

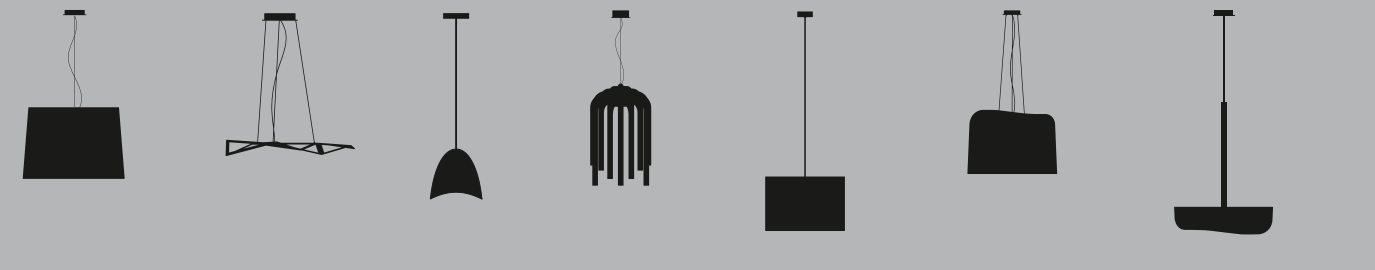

GRACE P 22 STARLIGHT P 28 MIRAGE P 36 PIPES P 42 HALF MOON P 66 OLA P 86 OLA FLY P 90

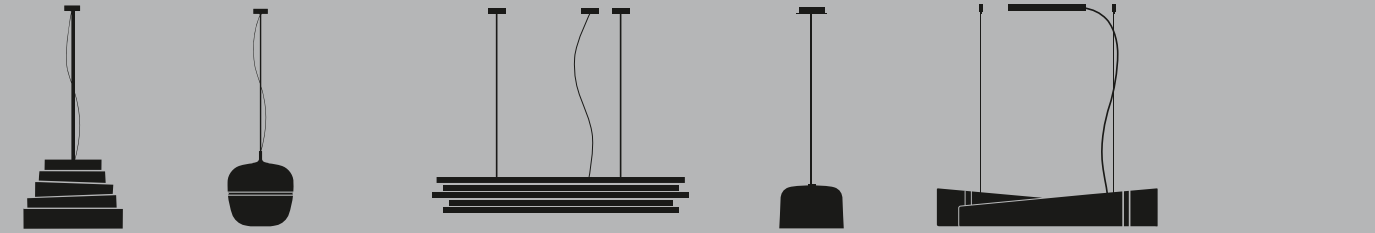

BABEL P 112 AFRA P 124 ESCAPE P 146 ADD P 186 SVEVA P 194

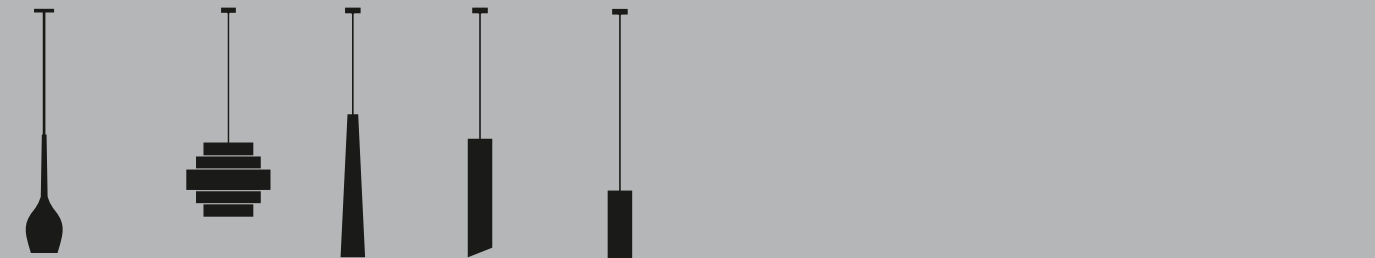

GOUT P 200 SUN P 204 DRINK P 220 SLICE P 226 TUBE P 240

PARETE
WALL
APPLIQUE
WANDLEUCHTE



STARLIGHT P 32 OLA SLIM P 94 ESCAPE P 152 ESCAPE P 152 ESCAPE P 154 ESCAPE Cube P 156 TUPLA P 160



SHINE P 168 TURN MEI P 174 ALALUNGA P 178 SHADOW P 182 TUBE P 246

FABRIXX / TECHNOLOGY

Il tessuto si trasforma grazie ad un innovativo processo produttivo chiamato Fabrixx. Karboxx ha realizzato un nuovo concetto di paralume che unisce la tradizione e la bellezza estetica del tessuto alla praticità e durabilità dei materiali più resistenti. La tecnologia Fabrixx consente di fondere il tessuto come il lino naturale alla fibra di vetro, conservandone le caratteristiche estetiche tipiche come la trasparenza e la diffusione della luce, aggiungendo elementi quali indeformabilità, resistenza ai liquidi, facilità di pulizia ed assenza di qualsiasi manutenzione per una durata nel tempo infinita.

Dank eines neuen, innovativen Produktionsprozesses entstand aus Stoff ein neues Produkt namens Fabrixx. Karboxx hat ein innovatives Konzept für Lampenschirme entwickelt, das Tradition und Ästhetik des Stoffes mit der Belastbarkeit der resistentesten Materialien vereint. Die Technologie Fabrixx erlaubt es, Stoffe wie natürliches Leinen mit Glasfasern zu verschmelzen und gleichzeitig die typischen Merkmale wie Transparenz und Lichtverteilung des Leinens beizubehalten und mit Eigenschaften wie Formstabilität, Resistenz gegen Flüssigkeiten, leichte Pflege und eine auf Dauer überflüssige Instandhaltung zu vereinen.

Fabric is transformed through an innovative productive process called Fabrixx. Karboxx has created a new concept of lampshade that combines the tradition and aesthetic beauty of fabric with the practicality and durability of more resistant materials. Fabrixx technology combines fabric like natural linen with fibreglass, preserving its typical, essential features like transparency and the diffusion of light and adding non-deformability, resistance to liquids, ease of cleaning and the absence of any need for maintenance for an infinite period of time.

Le tissu se transforme grâce à un processus de production innovant appelé Fabrixx. Karboxx a mis au point un nouveau concept d'abat-jour qui allie la tradition et la beauté esthétique du tissu à la commodité et la durabilité des matériaux plus résistants. La technologie Fabrixx permet de fondre le tissu, comme le lin naturel, dans la fibre de verre, tout en conservant ses caractéristiques esthétiques typiques telles que la transparence et la diffusion de la lumière, tout en y ajoutant des éléments comme l'indéformabilité, la résistance aux liquides, la facilité de nettoyage et l'absence d'entretien pour une durée infinie.



GRACE /

Designed by Moreno De Giorgio

A volte il risultato di un design rigoroso e poetico nasce dal piacere quotidiano di ripensare le parti di un oggetto familiare e ben radicato nella memoria collettiva, per anticipare nuove necessità e tendenze, in un abile e mai scontato equilibrio tra innovazione tecnologica e semplice eleganza formale. Grace parte da una completa rilettura della tradizionale lampada con paralume, attraverso l'essenzialità del disegno unita alla praticità delle finiture, come la scelta del materiale del diffusore tessile, in lino con fibra di vetro e strutturalmente autoportante, grazie alla tecnologia Fabrixx sviluppata da Karboxx. Lo stelo verticale, non più ortogonale alla base, è caratterizzato da un gambo delicato e organico, al cui interno scorre il filo di alimentazione, che si stacca da una preziosa e leggera base ad anello, per crescere spontaneamente all'insù, verso il paralume contenente la luce, sospesa a mezz'aria. Scelta ardità, inusuale e carica di inventiva, fonte di nuove, inedite e gradevoli atmosfere.

Hin und wieder wird das Ergebnis eines rigorosen, poetischen Designs aus dem täglichen Bedürfnis heraus geboren, die Bestandteile eines wohl bekannten, im kollektiven Verständnis verankerten Gegenstandes neu zu überdenken um so neuen Tendenzen und Bedürfnissen in einem faszinierenden Gleichgewicht zwischen innovativer Technologie und schlichter, formeller Eleganz vorzugreifen. Grace interpretiert die traditionelle Leuchte durch ein essentielles Design in Verbindung mit der Alltagstauglichkeit der Materialien des, dank der von Karboxx entwickelten Technologie Fabrixx, selbsttragenden Leuchtschirmes aus Leinen und Glasfasern. Das Gestell wächst aus seiner runden Basis zielstrebig nach oben zum Lampenschirm hin. Eine gewagte, außergewöhnliche Kombination als Quell für angenehme, unerforschte Kreationen neuer Atmosphären

Sometimes rigorous, poetic design is the result of a daily pleasure of redesigning the parts of a familiar object that is well-rooted in collective memory, to anticipate new needs and trends, in a capable and never banal equilibrium between high tech innovation and simple formal elegance. Grace begins with a complete reinterpretation of a traditional lamp with a lampshade, through the essential nature of the design, combined with the practicality of the finishes, like the choice of material for the fabric diffuser (linen and fibreglass) which is structurally self-supporting, thanks to Fabrixx technology developed by Karboxx. The vertical stem, which is no longer perpendicular to the base, features a delicate, organic stalk that contains the wiring, which detaches from a fine, light ring-shaped base to move to grow spontaneously upwards, towards the lampshade containing the light, suspended in the air. A courageous, unusual choice full of inventiveness, which is the source of delightful, and brand new concept's.

Parfois, le résultat d'un design rigoureux et poétique naît du plaisir quotidien de réinventer les éléments d'un objet familier et profondément enraciné dans la mémoire collective, pour anticiper les nouveaux besoins et les tendances, dans un équilibre habile et jamais évident entre innovation technologique et simple élégance formelle. Grace est née d'une relecture complète de la lampe traditionnelle avec abat-jour, à travers l'essence du dessin et la commodité des finitions, comme le choix du matériau du diffuseur textile, en lin avec fibre de verre et structurellement autoporteur, grâce à la technologie Fabrixx développée par Karboxx. La tige verticale, non plus orthogonale à la base, est caractérisée par un pied délicat et organique, à l'intérieur duquel passe le fil de l'alimentation, qui se détache d'une base en anneau précieuse et légère, pour ensuite pousser spontanément vers le haut, vers l'abat-jour contenant la lumière, comme suspendue dans l'air. Choix courageux, insolite et plein d'invention, source d'atmosphères nouvelles, inédites et agréables.





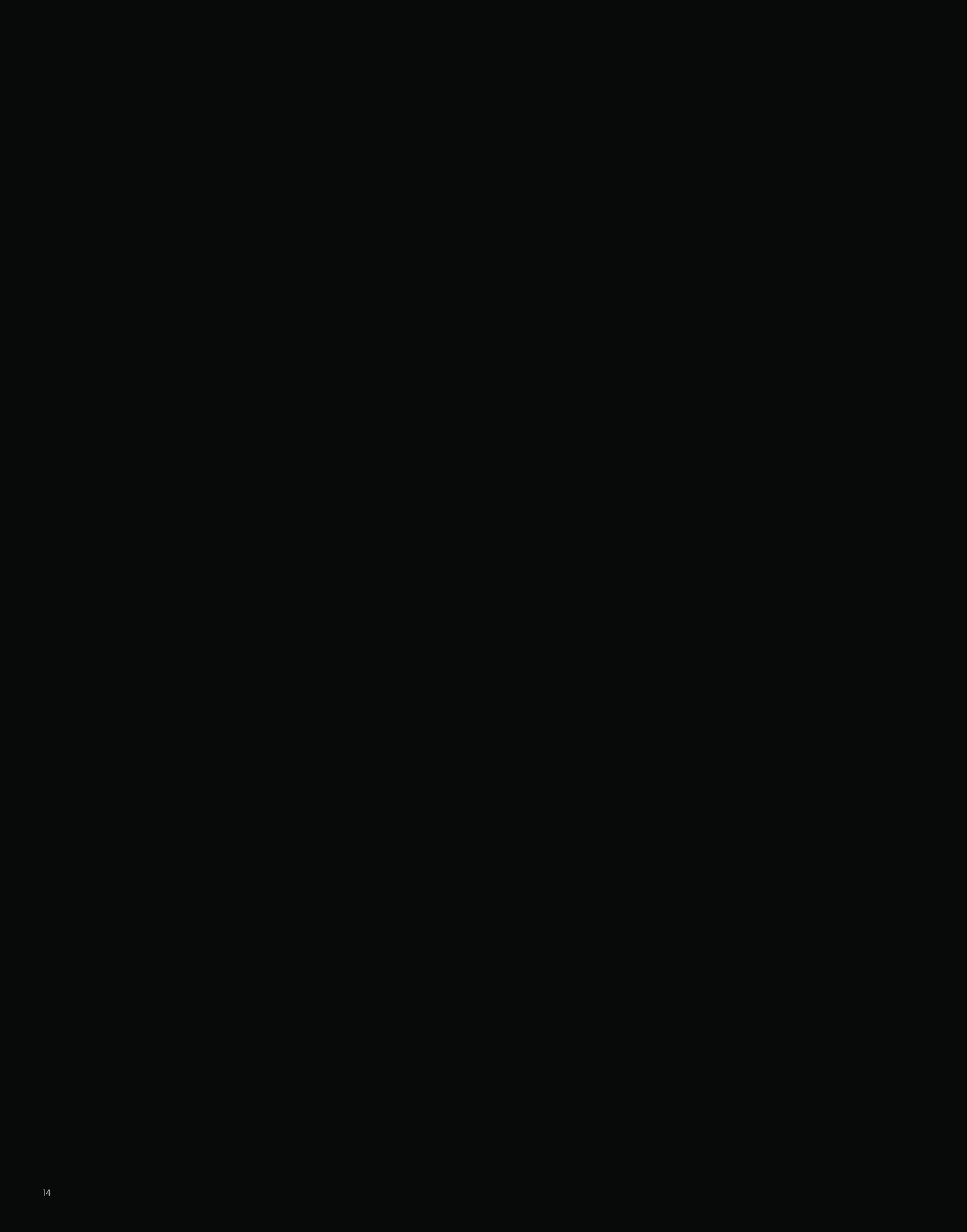

Lampada da terra con struttura in metallo verniciato colore scuro; paralume in lino naturale e fibra di vetro (tecnologia Fabrixx).

Floor lamp with metal structure painted in a dark colour; shade in natural linen and fibreglass (Fabrixx technology).

Lampadaire avec structure en métal laqué couleur sombre et abat-jour en lin naturel et fibre de verre (technologie Fabrixx).

Bodenleuchte mit Metallgestell (schwarz halbgänzend lackiert); Leuchtschirm in Naturleinen und Glasfaser (Technologie Fabrixx).

Grace / Terra / Floor / Lampadaire / Stehleuchte

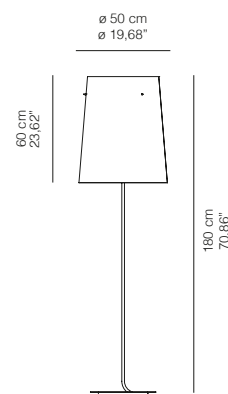

GRACE / Designed by Moreno De Giorgio

GRACE	Terra / Floor		SORGENTI LUMINOSE / LIGHT SOURCES		
	MISURE / DIMENSIONS		FLUO		
	CM.	INCHES	LED		
20TRIIFL	50ø x 60-180H	19,68ø x 23,62-70,86H	3x33W E27	3x16W E27	
			max 3x60W E27		
	COLORI / COLOURS		CERTIFICATIONS		
	Lino naturale e fibra di vetro - Tecnologia Fabrixx / Natural linen and fibreglass - Fabrixx Technology				
	OPZIONI / OPTIONS				
DITR	Dimmer				

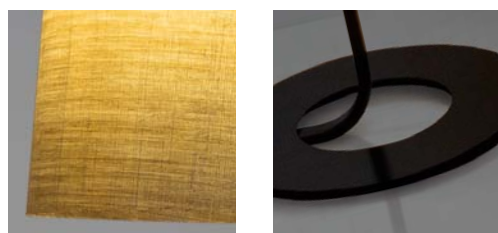



Lampada da tavolo, piccola o grande con struttura in metallo verniciato colore scuro; paralume in lino naturale e fibra di vetro (tecnologia Fabrixx).

Small or big table lamp with metal structure painted in a dark colour; shade in natural linen and fibreglass (Fabrixx technology).

Petite ou grande lampe de table avec structure en métal laqué couleur sombre. Abat-jour en lin naturel et fibre de verre (technologie Fabrixx).

Tischleuchte (klein oder groß) mit Metallgestell (schwarz halbgänzend lackiert); Leuchtschirm in Naturleinen und Glasfaser (Technologie Fabrixx).

Grace / Tavolo / Table / Table / Tischleuchte

GRACE / Designed by Moreno De Giorgio

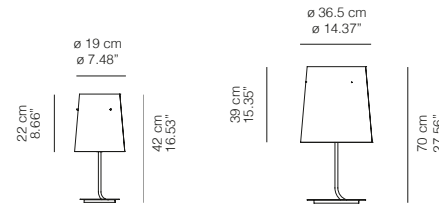

GRACE	Tavolo grande / Table grande		SORGENTI LUMINOSE / LIGHT SOURCES		CERTIFICATIONS
	MISURE / DIMENSIONS		FLUO		
	CM.	INCHES	LED		
20TV11FL	36,5ø x 39-70H	14,37ø x 15,35-27,56H	2x20W E27	2x10W E27	
			max 2x60W E27		
	COLORI / COLOURS				
	Lino naturale e fibra di vetro - Tecnologia Fabrixx / Natural linen and fibreglass - Fabrixx Technology				
GRACE	Tavolo piccola / Table piccola		SORGENTI LUMINOSE / LIGHT SOURCES		CERTIFICATIONS
	MISURE / DIMENSIONS		FLUO		
	CM.	INCHES	LED		
20TV12FL	19ø x 22-42H	7,48ø x 8,66-16,53H	1x20W E27	1x10W E27	
			max 1x40W E27		
	COLORI / COLOURS				
	Lino naturale e fibra di vetro - Tecnologia Fabrixx / Natural linen and fibreglass - Fabrixx Technology				

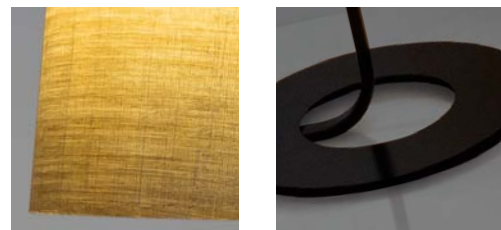







Lampada a sospensione con paralume in lino naturale e fibra di vetro (tecnologia Fabrixx) con diffusore inferiore in metacrilato opalino.

Suspended lamp with shade in natural linen and fibreglass (Fabrixx technology) and bottom diffuser in opaline methacrylate.

Lampe à suspension avec abat-jour en lin naturel et fibre de verre (technologie Fabrixx) et diffuseur en méthacrylate opale.

Pendelleuchte mit Leuchtschirm in Naturleinen und Glasfaser (Technologie Fabrixx), Diffusor aus mattem Methacrylat.

GRACE / Designed by Moreno De Giorgio

GRACE	Sospensione / Suspended		SORGENTI LUMINOSE / LIGHT SOURCES	
	MISURE / DIMENSIONS		FLUO	LED
	CM.	INCHES		
20SP11FL	50ø x 35H	19,68ø x 13,78H	3x33W E27 	3x16W E27 
			max 3x60W E27	
	COLORI / COLOURS		CERTIFICATIONS	
	Lino naturale e fibra di vetro - Tecnologia Fabrixx / Natural linen and fibreglass - Fabrixx Technology		  	

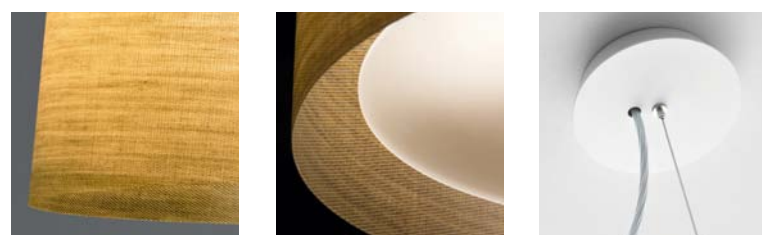
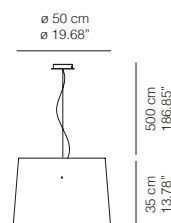

STARLIGHT /

Designed by Serena Papait

Starlight è una collezione di lampade dall'aspetto esile ma deciso, dove gli elementi geometrici vengono accostati creando un effetto dinamico.

La tecnologia utilizzata per l'illuminazione è il LED, disposto in modo tale da creare una luce indiretta e soft, ma al tempo stesso performante e diffusa. Questa collezione, nelle versioni da parete, sospensione e soffitto, può essere personalizzata nell'installazione a seconda degli spazi e dell'effetto che si vuole ottenere, dando vita anche a soluzioni più scenografiche accostandone diverse insieme.

Starlight ist eine Leuchtenkollektion mit zartem aber selbstbewusstem Design. Eine gelungene Anordnung geometrischer Figuren erzeugt eine ganz eigenständige Dynamik. Das indirekte Licht ist weich und verströmt eine angenehme Atmosphäre. Die Kollektion bietet Decken-, Wand- und Pendelleuchten die, passend zu den Räumlichkeiten, entsprechend der eigenen Bedürfnisse durch Zusammenstellen verschiedener Exemplare eigene Szenarien bilden.

Starlight is a collection of lamps with a slender, yet striking appearance, where geometric elements are combined to create a dynamic effect. LED technology is used for lighting, placed so as to create a soft, indirect light that is also high performance and diffused. This collection, with its wall, suspension and ceiling versions, can be customised for installation according to the spaces and the effect you want to create, also producing spectacular solutions by combing different versions.

Starlight est une collection de lampes à l'aspect fluide mais incisif, dans laquelle la combinaison d'éléments géométriques crée un effet dynamique. La LED, technologie utilisée pour l'éclairage, est disposée de sorte à créer une lumière indirecte et douce, mais aussi efficace et diffuse. Cette collection, disponible en version murale, suspension ou plafonnier, bénéficie d'une installation personnalisable en fonction des espaces et de l'effet désiré : la combinaison de plusieurs lampes peut également créer des solutions plus théâtrales.

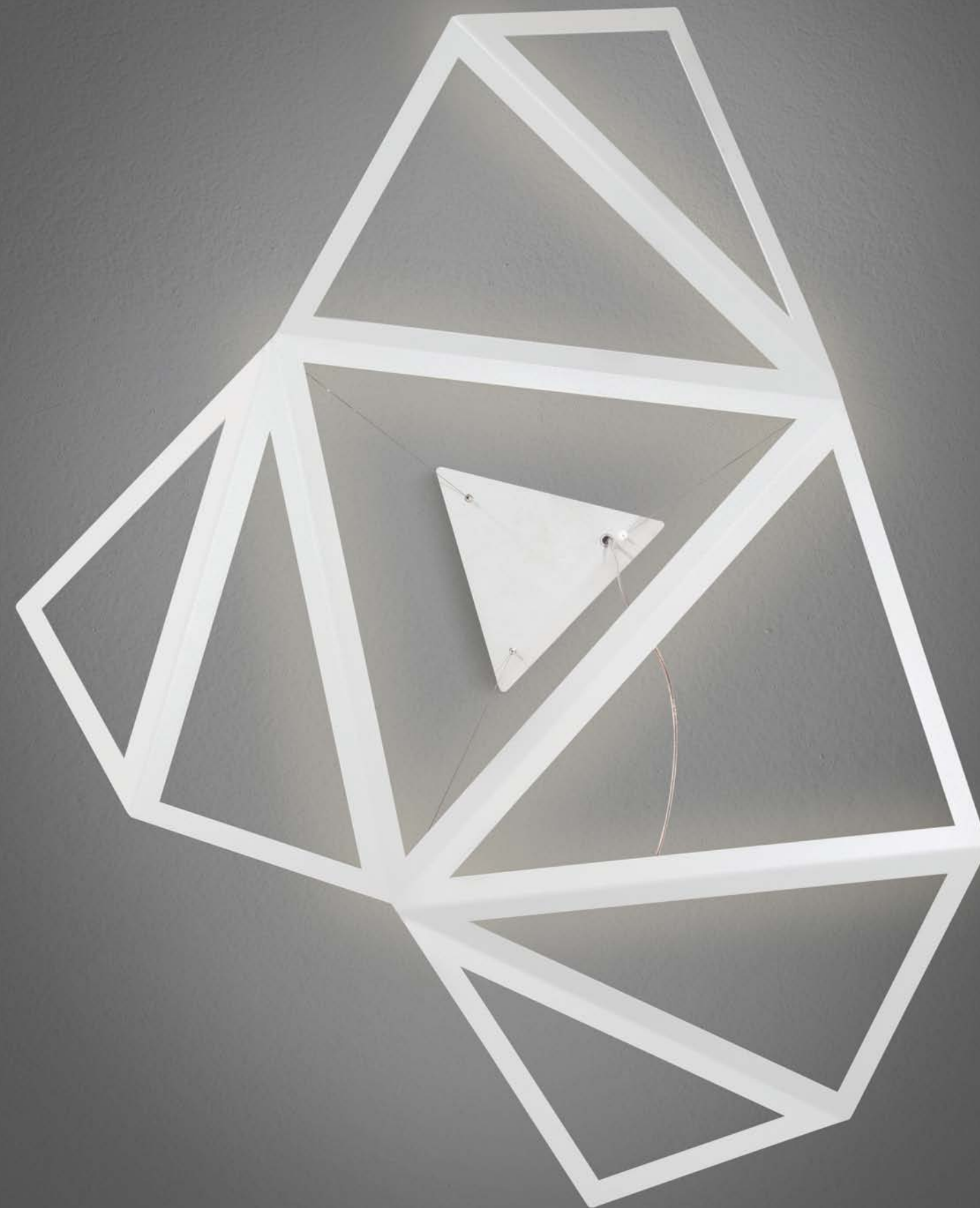



Lampada da sospensione in alluminio, verniciato bianco o antracite. Illuminazione LED luce calda con diffusione indiretta e soft. Dimmerabile 1-10V.

Suspended lamp in white or anthracite painted aluminium. Warm indirect and diffuse reflection though LED light. Dimmer 1-10V.

Lampe à suspension en alu laqué blanc ou anthracite. Source LED à lumière chaude avec diffusion indirecte et douce. Avec variateur d'intensité 1-10V.

Pendelleuchte aus Aluminium, weiss oder Anthrazit lackiert. Warmes LED-Licht mit indirekter Ausstrahlung. Dimmbar 1-10 V.

STARLIGHT / Designed by Serena Papait

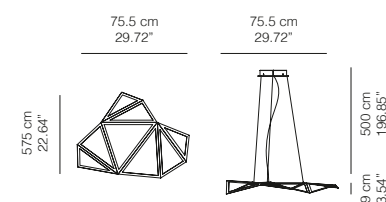

STARLIGHT	Sospensione/ Suspended		SORGENTI LUMINOSE / LIGHT SOURCES	
	MISURE / DIMENSIONS		LED	
	CM	INCHES	44W - Lumen 3500 - 2700K	
	75,5 x 57,5 x 9H	29,72 x 22,64 x 3,54H	LED INCLUSO / LED INCLUDED	
	COLORI / COLOURS		CERTIFICATIONS	
22SP01LW	Alluminio verniciato Bianco / White painted aluminium		CE IP 20	
22SP01LG	Alluminio verniciato Antracite / Anthracite painted aluminium			



LED

22SP01LW

22SP01LG

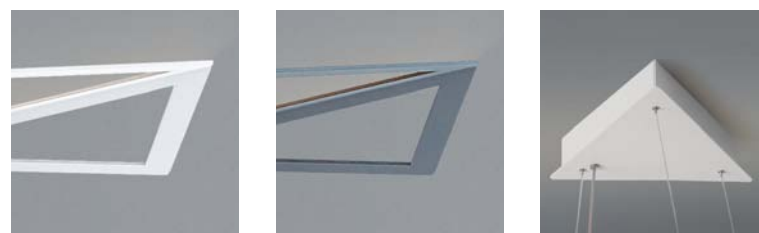

Starlight / Sospensione / Suspended / Suspension / Pendelleuchte

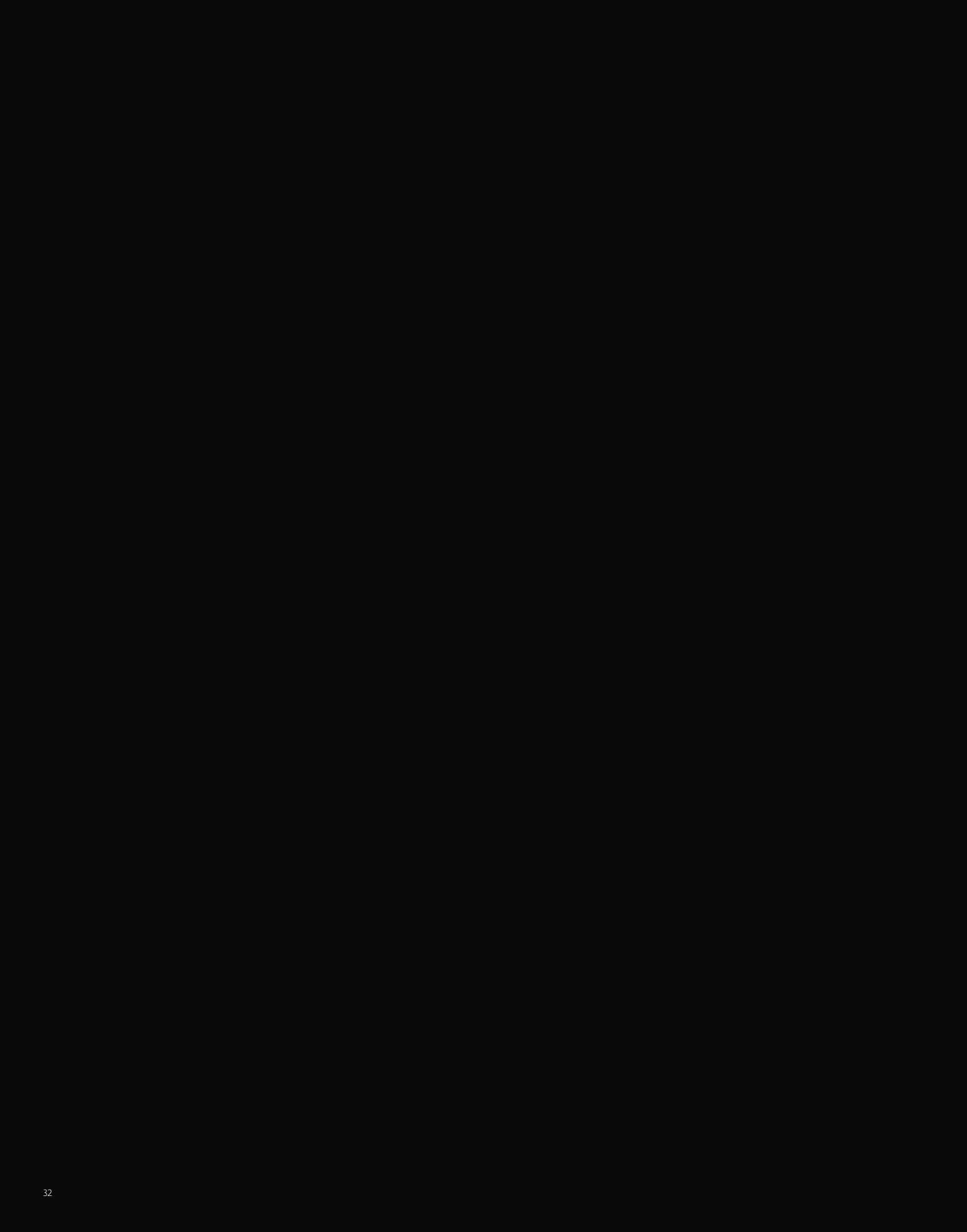

Lampada da parete in alluminio, verniciato bianco o antracite. Illuminazione LED luce calda con diffusione indiretta e soft.

Wall-mounted aluminium lamp, painted in white or anthracite. Warm, indirect and diffuse reflection through LED light.

Wandleuchte aus Aluminium, weiss oder Anthrazit lackiert. Warmes LED-Licht mit indirekter Ausstrahlung.

Applique en alu laqué blanc ou anthracite. Source LED à lumière chaude avec diffusion indirecte et douce.

Starlight / Parete / Wall-mounted / Applique / Wandleuchte

STARLIGHT / Designed by Serena Papait

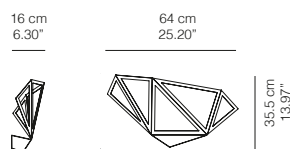

STARLIGHT	Parete / Wall			
	MISURE / DIMENSIONS		SORGENTI LUMINOSE / LIGHT SOURCES	
	CM	INCHES	LED	
	64 x 35,5 x 16	25,2 x 13,97 x 6,3	19W - Lumen 2000 - 2700K	
			LED INCLUSO / LED INCLUDED	
	COLORI / COLOURS		CERTIFICATIONS	
22PA01LW	Alluminio verniciato Bianco / White painted aluminium			
22PA01LG	Alluminio verniciato Antracite / Anthracite painted aluminium			

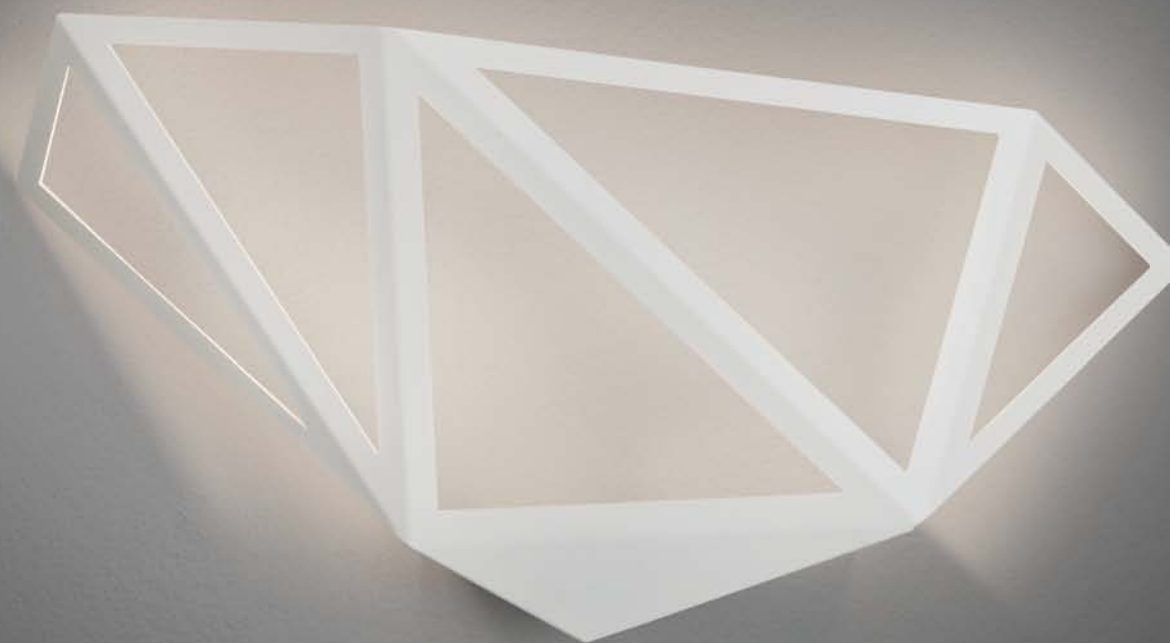

LED

22PA01LW



22PA01LG

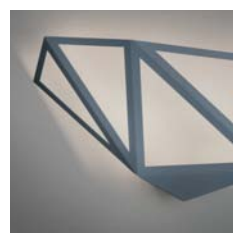

MIRAGE /

Designed by David Dolcini

“Volevo racchiudere un forte dinamismo all'interno di un oggetto atemporale, dalle proporzioni eleganti e dal profilo femminile”. Grazie al suo profilo sinuoso e alla relazione che si genera tra le due finiture, interna ed esterna, la percezione della luce e della lampada stessa muta di volta in volta a seconda della posizione di chi la osserva. Caratterizzata dall'utilizzo di una sorgente LED di ultima generazione e da un paralume in alluminio con una doppia finitura (esterna e interna), Mirage è una lampada pensata per arredare, decorare ambienti e spazi privati e progetti contract.

Mirage entspringt dem Bedürfnis, eine starke Dynamik in einem zeitlosen Element mit eleganten Proportionen und einem femininem Profil zu vereinigen. Dank des sinusförmigen Profils und des Verhältnisses das sich zwischen der inneren und äußeren Ausführung bildet wird erscheinen das Licht und die Mirage selbst je nach Blickpunkt in stets veränderter Form. Mirage wird durch LED der neuesten Generation, sowie einen Aluminiumschirm mit unterschiedlicher Ausführung für Innen- und Außenseite charakterisiert. Das Ergebnis ist eine dekorative Leuchte für den Heim- und Objektbereich.

“I wanted to encapsulate strong dynamism inside a timeless object with elegant, feminine proportions”. Thanks to its sinuous outline and the relationship between the inner and outer finishes, the perception of the light and the lamp itself changes according to the position of the observer. It features a last generation LED bulb and an aluminium lampshade with a dual inner and outer finish. Mirage is a lamp designed to furnish, decorate homes, private spaces and contract projects.

« Je voulais capturer un dynamisme fort dans un objet intemporel, aux proportions élégantes et au profil féminin ». Grâce à son profil sinueux et au rapport né des deux finitions, interne et externe, la perception de la lumière et de la lampe même change perpétuellement selon la position de l'observateur. Caractérisée par l'utilisation de LED de dernière génération et par un abat-jour en aluminium avec une double finition (externe et interne), Mirage est une lampe pensée pour meubler, décorer des pièces et des espaces privés ou encore pour des projets de gros marchés.





Lampada a sospensione in metallo con finiture cromo, rame, ottone o bianco lucido. Rosone in tinta con il paralume. Sorgente LED 220-240 luce calda. Dimmerabile a taglio di fase.

Suspended metal lamp in chrome, copper, brass or shiny white finish. Ceiling rose in the same finish. LED 220-240 warm light source. AC phase-cut dimming.

Lampe à suspension en métal, finition chrome, cuivre, laiton ou blanc brillant. Rosace dans la même finition que l'abat-jour. Source LED 220-240 à lumière chaude. Avec variateur d'intensité.

Pendelleuchte mit integriertem Trafo aus Metall in Chrom, Messing, Kupfer und weiß lackiert. Baldachin in den gleichen Ausführungen. Warmes LED Licht (220-240). Dimmbar.

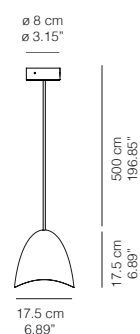

MIRAGE/

Designed by David Dolcini

MIRAGE	Sospensione / Suspended		SORGENTI LUMINOSE / LIGHT SOURCES		Dimmer a taglio di fase
	MISURE / DIMENSIONS		LED		AC phase-cut dimming
	CM	INCHES	8,7W - Lumen 800 - 2700K		
	17,5Ø x 17,5	6,89 x 6,89	LED INCLUSO / LED INCLUDED		
	COLORI / COLOURS		CERTIFICATIONS		
24SP01LC	Metallo finitura Cromato / Chrome finish metal		CE IP 20 CLASSE 1		
24SP01LR	Metallo finitura Rame / Copper finish metal				
24SP01LT	Metallo finitura Ottone / Brass finish metal				
24SP01LW	Metallo verniciato Bianco lucido / Shiny White painted metal				

LED

24SP01LC

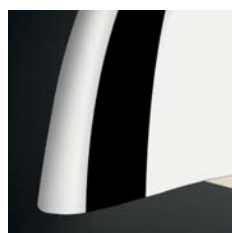

24SP01LR

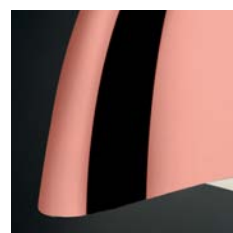

24SP01LT

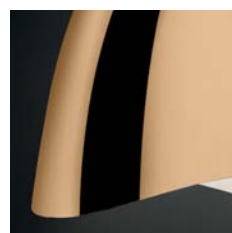

24SP01LW



Mirage / Sospensione / Suspended / Suspension / Pendelleuchte

PIPES /

Designed by Thomas Feichtner

Tubi accavallati uno sopra l'altro a formare una cascata. Questo raffinato e semplice concetto è alla base della progettazione del designer austriaco Thomas Feichtner. Tubi in alluminio di diverse lunghezze, piegati ed accavallati con una leggera angolazione, a cui ad ogni estremità è stata posta una sorgente LED. I singoli segmenti dalle linee bidimensionali sono disposti a ventaglio a formare una circonferenza, ottenendo così un unico corpo, un oggetto geometrico e leggero.

Rohre zu einer Leuchte übereinander gestapelt - so einfach, aber nicht minder raffiniert ist der Entwurf des österreichischen Designers Thomas Feichtner für den italienischen Leuchtenhersteller Karboxx. Einzelne gebogene und unterschiedlich lange Rohrsegmente sind jeweils mit LEDs als Leuchtmittel bestückt und im leichten Winkel zueinander aufeinander gestapelt. Das einzelne Segment, als zweidimensionale Linie, ergibt erst in der Rotation einen runden, geschlossenen Körper. Allein durch das Addieren der Segmente entsteht ein geometrisches Lichtobjekt.

Pipes one crossed over the other to form a cascade. This simple and elegant concept is the basis of projects by Austrian designer Thomas Feichtner. Aluminium pipes of various lengths bent and crossed at a slight angle, with an LED light source at every end. The individual segments with their two-dimensional lights are arranged in a fan-shape to form a circumference, producing a single body, a light, geometric object.

Des tubes qui se chevauchent pour former une cascade. C'est ce concept simple et raffiné qui est à la base de l'idée du designer autrichien Thomas Feichtner. Des tubes en aluminium de différentes longueurs, pliés et se chevauchant avec une légère inclinaison, dotés à chaque extrémité d'une LED. Chaque segment aux lignes bidimensionnelles est disposé en éventail pour former une circonférence, obtenant ainsi un corps unique, un objet géométrique et léger.







Lampada a sospensione composta da tubi in alluminio piegati e accavallati. Struttura verniciata in quattro colori (bianco, antracite, rame, oro). Sorgenti LED luce calda su ciascuna estremità.

Suspended lamp made by aluminium pipes bent and crossed one over the other. Structure painted in four colours (white, anthracite, copper, gold). LED warm light source on each end.

Lampe à suspension composée de tubes pliés qui se chevauchent. Structure laquée en quatre couleurs (blanc, anthracite, cuivre, or). Source LED à lumière chaude à chaque extrémité.

Pendelleuchte aus einzelnen gebogenen und unterschiedlich lange Rohrsegmenten, jeweils mit LEDs (warmes Licht) als Leuchtmittel punktuell bestückt. Ausführungen: weiss, Anthrazit Kupfer und Gold lackiert.

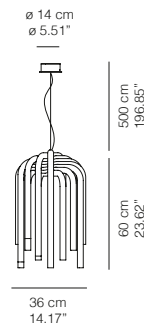

PIPES/

Designed by Thomas Feichtner

PIPES		Sospensione / Suspended		SORGENTI LUMINOSE / LIGHT SOURCES		CERTIFICATIONS		
MISURE / DIMENSIONS		LED		16x1W - Lumen 1400 - 2700K ☼		CE IP 20		
CM	INCHES							
36ø x 60H	14,17ø x 23,62H			LED INCLUSO / LED INCLUDED				
COLORI / COLOURS								
23SP1L2	Alluminio verniciato Bianco / Matt White painted aluminium							
23SP1L1	Alluminio verniciato Antracite / Matt Anthracite painted aluminium							
23SP1L3	Alluminio verniciato Oro lucido / Shiny Gold painted aluminium							
23SP1L4	Alluminio verniciato Rame / Copper painted aluminium							



LED

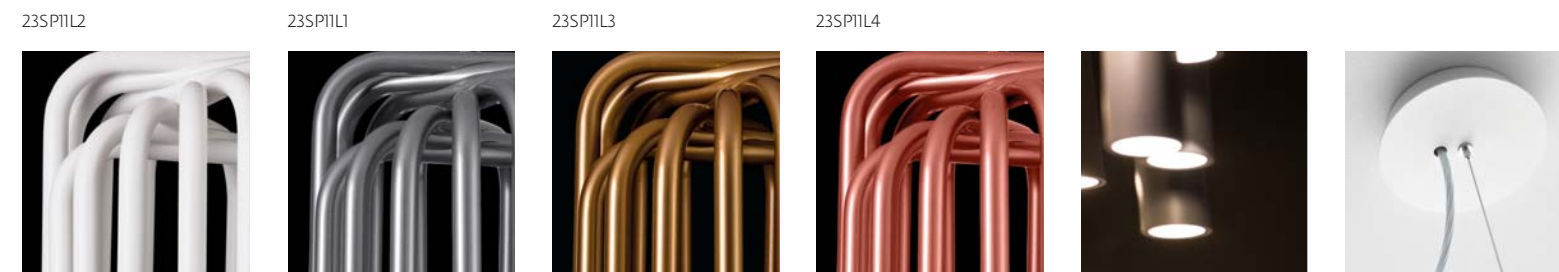

OPPO /

Designed by Thomas Feichtner

Fino ad oggi, molte lampade hanno richiesto paralumi o riflettori per diffondere e direzionare la luce. Non le lampade Oppo: grazie alla più recente tecnologia LED, la sorgente di luce funge anche da diffusore, offrendo una piacevole luce diretta ed indiretta. Si tratta di una superficie di illuminazione sottile appena 10 mm posta in cima ad una costruzione rettangolare. Da qui il nome Oppo per "opposite", "opposto", come un riferimento alla sua illuminazione bidirezionale. Il concetto di design puro e minimalista rende questa lampada speciale e funzionale anche nell'uso quotidiano, in quanto grazie alla mensola, diventa oggetto pratico e d'arredo, proposto in due diverse altezze: 175 e 120 cm.

Der italienische Leuchtenhersteller Karboxx entwickelte gemeinsam mit dem Designer Thomas Feichtner die Stehleuchte Oppo. Bisher benötigten viele Leuchten Lampenschirme, um das Licht greller und punktueller Lichtquellen zu streuen. Nicht so bei Oppo Light: Das neue Konzept der Leuchte verzichtet gänzlich auf einen Reflektor. Dank neuester LED-Technologie ist die Lichtquelle gleichermaßen auch Diffuser und ermöglicht ein angenehmes, direktes sowie indirektes Licht auf Decke und Boden. Daher auch der Name Oppo, wie opposite (en) oder opposto (it), abgeleitet aus dem gegenseitigen Ausleuchten. Das klare und minimalistische Gestaltungskonzept geht ganz auf das Wesentliche der Leuchte ein. Eine dünne – nur 10 mm starke – Lichtfläche, die von einer rechteckigen Konstruktion getragen wird. Oppo Light wird in zwei verschiedenen Höhen angeboten. In 175 und 120 cm.

Until today, many lamps have needed lampshades or reflectors to spread or direct light. Not Oppo lamps, thanks to the most recent LED technology. The light source also acts as a diffuser, offering both pleasant direct and indirect light. It has a thin light surface, just 10 mm, placed on the top of a rectangular body. This was the inspiration for its name: Oppo for 'opposite', as a reference to its bi-directional lighting. The pure, minimalist design concept makes this lamp special and functional, even in everyday use, as thanks to its shelf it becomes a practical furnishing item, available in two heights: 175 and 120 cm.

Jusqu'à aujourd'hui, la plupart des lampes nécessitaient un abat-jour ou un réflecteur pour diffuser et diriger la lumière. Les lampes Oppo en sont dépourvues : grâce à la technologie à LED la plus récente, la source de lumière sert également de diffuseur pour offrir une agréable lumière directe et indirecte. Il s'agit d'une superficie d'éclairage fine, de 10 mm à peine, située au sommet d'une construction rectangulaire. D'où son nom Oppo, comme « opposite », « opposé », en référence à son éclairage bidirectionnel. Le concept de design pur et minimaliste rend cette lampe spéciale et fonctionnelle, également pour une utilisation quotidienne, grâce à sa tablette, pratique et décorative. Proposée en deux hauteurs différentes : 175 cm et 120 cm.





Lampada da terra composta da una composizione rettangolare in metallo verniciato antracite e un sottile diffusore in metacrilato HR per un'illuminazione bidirezionale (diretta e indiretta). Sorgente LED luce calda. Dimmerabile.

Floor lamp made by a rectangular structure in anthracite painted metal and a thin HR methacrylate diffuser that enables a bidirectional lighting (both direct and indirect). LED warm light source. Dimmable.

Lampadaire constitué par une construction rectangulaire en métal laqué anthracite et un fin diffuseur en méthacrylate HR pour un éclairage bidirectionnel (direct et indirect). Source LED à lumière chaude. Avec variateur d'intensité.

Stehleuchte besteht aus einer rechteckigen Metallkonstruktion und einer bidirektionaler Diffusor aus Methacrylat. Direkte sowie indirekte LED-Beleuchtung warmes Licht. Dimmbar.

Oppo / Terra / Floor / Lampadaire / Stehleuchte

OPPO / Designed by Thomas Feichtner

OPPO	Terra / Floor		SORGENTI LUMINOSE / LIGHT SOURCES		with dimmer
	MISURE / DIMENSIONS				
	CM	INCHES	LED		
OPPO 120	38 x 38 x 118H	14,96 x 14,96 x 46,45H	33W - Lumen 3500 - 2700K		
26TRI1L1			LED INCLUSO / LED INCLUDED		
OPPO 175	38 x 38 x 178H	14,96 x 14,96 x 70,08H	33W - Lumen 3500 - 2700K		
26TRI2L1			LED INCLUSO / LED INCLUDED		
	COLORI / COLOURS		CERTIFICATIONS		
	Struttura in metallo verniciato Antracite / Anthracite painted metal structure		CE IP 20 CLASSE 1		
	Diffusore in HR metacrilato satinato / Satin HR methacrylate diffuser				

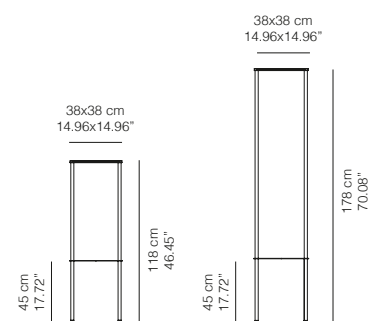

LED



HALF MOON /

Design Enrico Franzolini with Vicente Garcia Jimenez

Collezione composta da lampada da tavolo in due dimensioni, grande e mini, terra e sospensione. Paralume in fibra di carbonio con interno verniciato in più colori. Stelo in carbonio e base in alluminio verniciata nera.

A collection made up of a table lamp in two sizes, large and mini, and a floor and hanging version. Shade in carbon fibre with interior painted in several colours. Carbon stem and base in black-painted aluminium.

Collection composée par suspension, lampadaire et lampe en deux dimension. Abat-jour en fibre de carbone laquée en 3 couleurs différentes. Tige en carbone et base en alu noir.

Kollektion Halfmoon bestehend aus Tischleuchte in 2 Ausführungen (GRANDE und MINI), Bodenleuchte und Pendelleuchte. Lampenschirm aus Kohlenstoff, innen in drei Ausführungen lackiert. Lampestander aus Kohlenstoff und Stütze aus Aluminium Schwarz lackiert.



Lampada da terra con paralume in fibra di carbonio verniciato internamente in tre colorazioni diverse. Stelo in carbonio e base in alluminio verniciato nero.

Floor lamp with shade in carbon fibre with interior painted in three different colours. Stem in carbon and base in black-painted aluminium.

Lampadaire avec abat-jour en fibre de carbone laquée en 3 couleurs différentes. Tige en carbone et base en alu noir.

Stehleuchte mit Lampenschirm aus Kohlenstoff, innen in drei Ausführungen lackiert. Lampestander aus Kohlenstoff und Stütze aus Aluminium Schwarz lackiert.

Half moon / Terra / Floor / Lampadaire / Stehleuchte

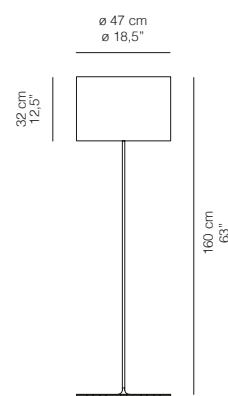

HALF MOON / Design Enrico Franzolini with Vicente Garcia Jimenez

HALF MOON	Terra / Floor		SORGENTI LUMINOSE / LIGHT SOURCES		
	MISURE / DIMENSIONS		FLUO		
	CM.	INCHES	LED		
	47ø x 32-160H	18,5ø x 12,5-63H	3x23W E27		3x16W E27
	COLORI / COLOURS		CERTIFICATIONS		
03TR16001	Fibra di carbonio / Carbon fibre: Nero / Black - interno Avorio / Ivory inside				
03TR16002	Fibra di carbonio / Carbon fibre: Nero / Black - interno Viola / Purple inside				
03TR16003	Fibra di carbonio / Carbon fibre: Nero / Black - interno Arancio / Orange inside				
	Diffusore in metacrilato opalino incluso / Diffuser in opaline methacrylate included / Diffuseur en méthacrylate opalin inclus				
	OPZIONI / OPTIONS				
DITR	Dimmer				

03TR16001



03TR16002



03TR16003

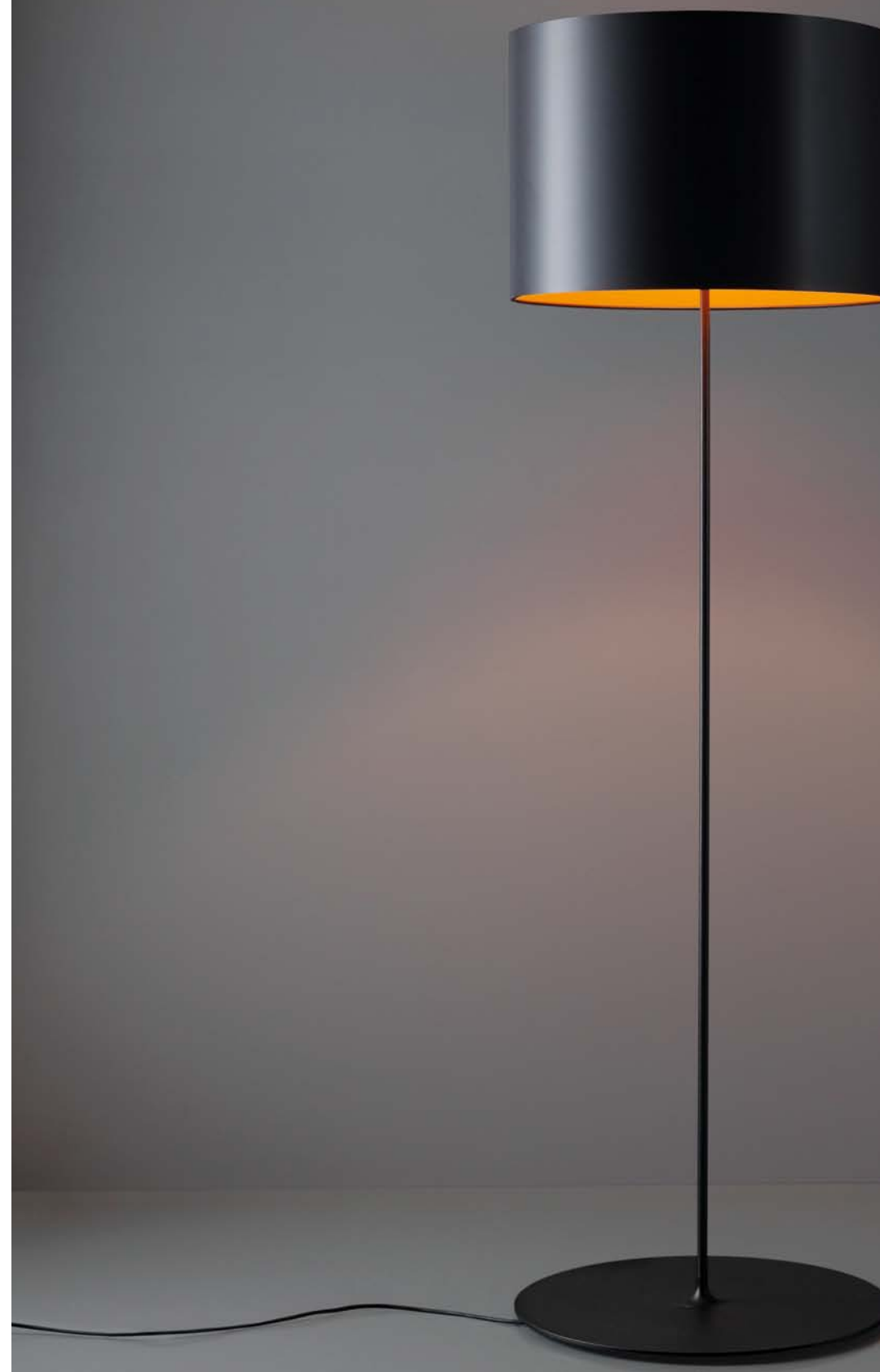



Lampada da tavolo con paralume in fibra di carbonio verniciato internamente in tre colorazioni diverse. Stelo in carbonio e base in alluminio verniciato nero.

Table lamp with shade in carbon fibre with interior painted in three different colours. Stem in carbon and base in black-painted aluminium.

Lampe de table avec abat-jour en fibre de carbone laquée en 3 couleurs différentes. Tige en carbone et base en alu noir.

Tischleuchte mit Lampenschirm aus Kohlenstoff, innen in drei Ausführungen lackiert. Lampestander aus Kohlenstoff und Stütze aus Aluminium Schwarz lackiert.

Half moon / Tavolo / Table / Table / Tischleuchte

HALF MOON / Design Enrico Franzolini with Vicente Garcia Jimenez

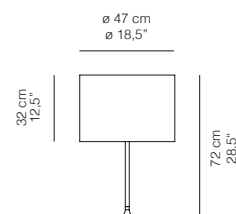

HALF MOON	Tavolo / Table		SORGENTI LUMINOSE / LIGHT SOURCES		CERTIFICATIONS
	MISURE / DIMENSIONS		FLUO	LED	
	CM.	INCHES			
	47ø x 32-72H	18,5ø x 12,5-28,5H	3x23W E27	3x16W E27	
	COLORI / COLOURS				
03TV03201	Fibra di carbonio / Carbon fibre: Nero / Black - interno Avorio / Ivory inside				
03TV03202	Fibra di carbonio / Carbon fibre: Nero / Black - interno Viola / Purple inside				
03TV03203	Fibra di carbonio / Carbon fibre: Nero / Black - interno Arancio / Orange inside				
	Con diffusore in metacrilato opalino / with diffuser in opaline methacrylate				
	OPZIONI / OPTIONS				
D1TV	Dimmer				

03TV03201



03TV03202



03TV03203



Lampada da tavolo con paralume in fibra di carbonio con interno e base verniciati in tre colorazioni diverse. Base e stelo in metallo.

Table lamp with shade in carbon fibre with interior and base painted in 3 different colours. Base and stem in metal.

Lampe de table avec abat-jour en fibre de carbone avec partie intérieure et base laquées en 3 couleurs différents. Base et tige en métal.

Tischleuchte mit Lampenschirm aus Kohlenstoff, innen und Lampestander in 3 Ausführungen lackiert. Lampestander und Stütze aus Metall.

Half moon mini / Tavolo / Table / Table / Tischleuchte

HALF MOON mini / Design Enrico Franzolini with Vicente Garcia Jimenez

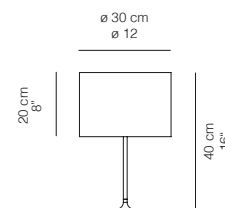

HALF MOON mini	Tavolo / Table		SORGENTI LUMINOSE / LIGHT SOURCES	
	MISURE / DIMENSIONS		HALOG.	
	CM.	INCHES		
	30ø x 20-40H	12ø x 8-16H	E-saver max 1x42W G9	
	COLORI / COLOURS		CERTIFICATIONS	
03TVL004	Fibra di carbonio / Carbon fibre: Nero / Black - interno Avorio / Ivory inside		□ ▽ CE IP 20	
03TVL005	Fibra di carbonio / Carbon fibre: Nero / Black - interno Arancio / Orange inside			
03TVL006	Fibra di carbonio / Carbon fibre: Nero / Black - interno Viola / Purple inside			



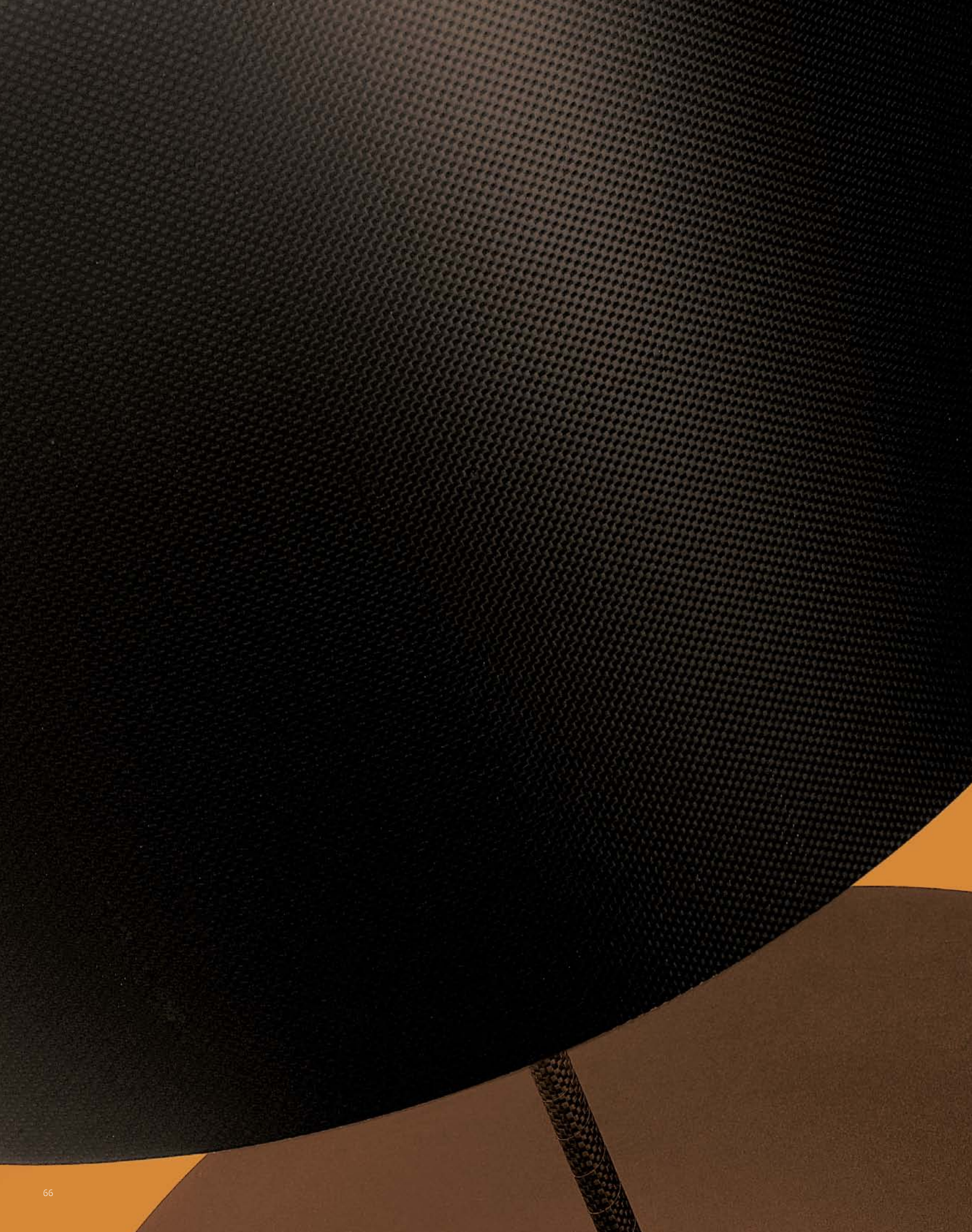

Lampada da sospensione
con paralume in fibra di carbonio
verniciato internamente in tre
colorazioni diverse.

Suspended lamp with shade
in carbon fibre with interior
painted in three different
colours.

Suspension avec abat-jour en
fibre de carbone laquée en 3
couleurs différentes.

Pendelleuchte mit Lampen-
schirm aus Kohlenstoff, innen
in drei Ausführungen lackiert.

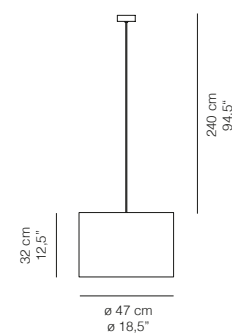

HALF MOON / Design Enrico Franzolini with Vicente Garcia Jimenez

HALF MOON	Sospensione / Suspended		SORGENTI LUMINOSE / LIGHT SOURCES		CERTIFICATIONS
	MISURE / DIMENSIONS		FLUO	LED	
	CM.	INCHES			
	47ø x 32-240H	18,5ø x 12,5-94,5H	3X23W E27	3x16W E27	
	COLORI / COLOURS				
03SP03201	Fibra di carbonio / Carbon fibre: Nero / Black - interno Avorio / Ivory inside				
03SP03202	Fibra di carbonio / Carbon fibre: Nero / Black - interno Viola / Purple inside				
03SP03203	Fibra di carbonio / Carbon fibre: Nero / Black - interno Arancio / Orange inside				
	Con diffusore in metacrilato opalino / with diffuser in opaline methacrylate				
	OPZIONI / OPTIONS				
5MT	Sospensione cablaggio lunghezza cavi mt. 5,00 / Suspended with longer cables mt. 5,00				

03SP03201



03SP03202



03SP03203



Half moon / Sospensione / Suspended / Suspension / Pendelleuchte

OLA /

Design Enrico Franzolini

Ola è la collezione nata dalle sensazioni del designer Enrico Franzolini: Karboxx le materializza attraverso nuove tecnologie e materiali. Una fibra di vetro che è risultato di un lungo processo di ricerca tecnologica e materica. Un materiale che crea atmosfere uniche filtrando la luce attraverso le sue forme. La luce chiara che illumina la notte, il sole cocente d'estate, la bellezza di un tramonto: Ola reinterpreta la luce degli elementi in tre misure e cinque finiture. Terra, tavolo, appoggio, sospensione, soffitto e parete: una collezione completa che utilizza lampadine LED ed a risparmio energetico.

Ola is the collection born from the sensations of the designer Enrico Franzolini: Karboxx materialized these sensations through new materials and technologies. A composite Fibreglass is the result of a long process of R&D. Beautiful atmospheres, shadows and lights filtered by the shape of the lamp. The bright light in the night, a hot sun in the summer, the beauty of a sunset: Ola reinterprets the light of elements in three sizes and five colors. Floor, suspended, table: a complete range using LED and energy saving bulbs.

Ola est la collection née de la sensibilité du Designer Enrico Franzolini: KARBOXX a concrétisé ses idées à travers de nouveaux matériaux et nouvelles technologies. Une longue étude de recherche et développement a permis la mise au point d'une nouvelle fibre de verre composite. Un matériau qui crée une atmosphère unique en filtrant la lumière à travers les formes de la lampe. La lumière brillante dans la nuit, un chaud soleil d'été, la beauté d'un coucher de soleil: Ola réinterprète la luminosité de chaque élément en trois tailles et cinq couleurs. Au sol, suspendue, à poser: une gamme complète utilisant des LEDs et des ampoules basse consommation.

Ola ist die Kollektion die aus den Eindrücken des Designers Enrico Franzolini geboren wurde: Karboxx materialisiert diese durch neue Technologien und Materialien. Eine Glasfaser ist das Ergebnis eines langen Forschungsprozesses in Bezug auf Technologie und Material. Ein Material, das das Licht durch seine Formen filtert und so einzigartige Atmosphären zu schaffen vermag. Das klare Licht das die Nacht erhellt, die gleißende Sonne, die Schönheit eines Sonnenunterganges: Ola interpretiert das Licht der Elemente in drei Abmessungen und in fünf Ausführungen. Stehlampe, Tischleuchte und Deckenleuchte: Eine komplette Kollektion die LED und Energiesparlampen verwendet.



Ola, un nome semplice per una lampada semplice.
 La perfezione imperfetta, la materia immateriale, la notte e il giorno, il sole e la luna, la realtà e il sogno. Paralume in fibra di vetro in cinque differenti colori e stelo in metallo verniciato antracite.
 Disponibile in altri colori a richiesta.

Ola, It's a simple name for a simple light. The imperfect perfection, the immaterial material, the night and the day, the sun and the moon, the reality and the dream. The shade in fibreglass is available in five different colors. Base in anthracite painted metal. On request any color available.

Ola, un nom simple pour une lampe simple. La perfection imparfaite, la matière immatérielle, la nuit et le jour, le soleil et la lune, la réalité et le rêve. Diffuseur en fibre de verre laquée en cinq finitions; base en métal anthracite. Sur demande disponible dans toutes les couleurs.

Ola, ein einfacher Name für eine einfache Lampe. Die unvollkommene Vollkommenheit, die immaterielle Materie, die Nacht und der Tag, die Sonne und der Mond, die Wirklichkeit und der Traum. Lampenschirm aus Glasfaserstoff lackiert und die Stütze aus Metall Anthrazit lackiert. Auf Wunsch auch in weiteren Ausführungen lieferbar.

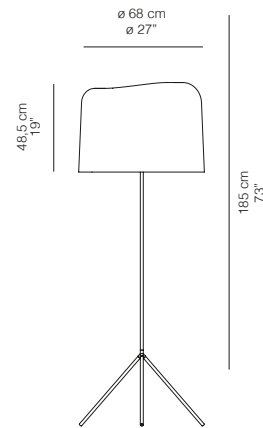

OLA / Design Enrico Franzolini

OLA	Terra / Floor		
MISURE / DIMENSIONS		SORGENTI LUMINOSE / LIGHT SOURCES	
CM.	INCHES	FLUO	LED
68ø x 48-185H	27ø x 19-73H	3x32W E27	3x16W E27
COLORI / COLOURS		CERTIFICATIONS	
09TR68F2	Fibra di vetro Bianca / White Fibreglass	CE IP 20	
09TR68F3	Fibra di vetro Rosso / Red Fibreglass		
09TR68F5	Fibra di vetro Arancio / Orange Fibreglass		
09TR68F6	Fibra di vetro Oro / Gold Fibreglass		
09TR68F7	Fibra di vetro Argento / Silver Fibreglass		
OPZIONI / OPTIONS			
DTR	Dimmer		



Ola / Terra / Floor / Lampadaire / Stehleuchte





Lampada da terra con paralume in fibra di vetro in cinque differenti colori e maniglia in metallo verniciato antracite. Disponibile in altri colori a richiesta.

Floor lamp with shade in fibre-glass, available in five different colors. Handle in anthracite painted metal. On request any color available.

Lampadaire avec diffuseur en fibre de verre laquée en cinq finitions poignée en métal anthracite. Sur demande disponible dans toutes les couleurs.

Stehleuchte mit Lampenschirm aus Glasfaserstoff lackiert und die Handhaben aus Metall Anthrazit lackiert. Auf Wunsch auch in weiteren Ausführungen lieferbar.

Ola move / Terra / Floor / Lampadaire / Stehleuchte

OLA move / Design Enrico Franzolini

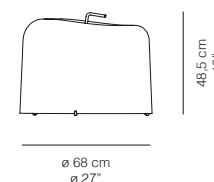

OLA move	Terra / Floor		SORGENTI LUMINOSE / LIGHT SOURCES		CERTIFICATIONS V CE IP 20
	MISURE / DIMENSIONS				
	CM.	INCHES	FLUO	LED	
	68ø x 48,5H	27ø x 19H	3x32W E27	3x16W E27	
	COLORI / COLOURS				
09AP68F2	Fibra di vetro Bianca / White Fibreglass				
09AP68F3	Fibra di vetro Rosso / Red Fibreglass				
09AP68F5	Fibra di vetro Arancio / Orange Fibreglass				
09AP68F6	Fibra di vetro Oro / Gold Fibreglass				
09AP68F7	Fibra di vetro Argento / Silver Fibreglass				
	OPZIONI / OPTIONS				
DITR	Dimmer				



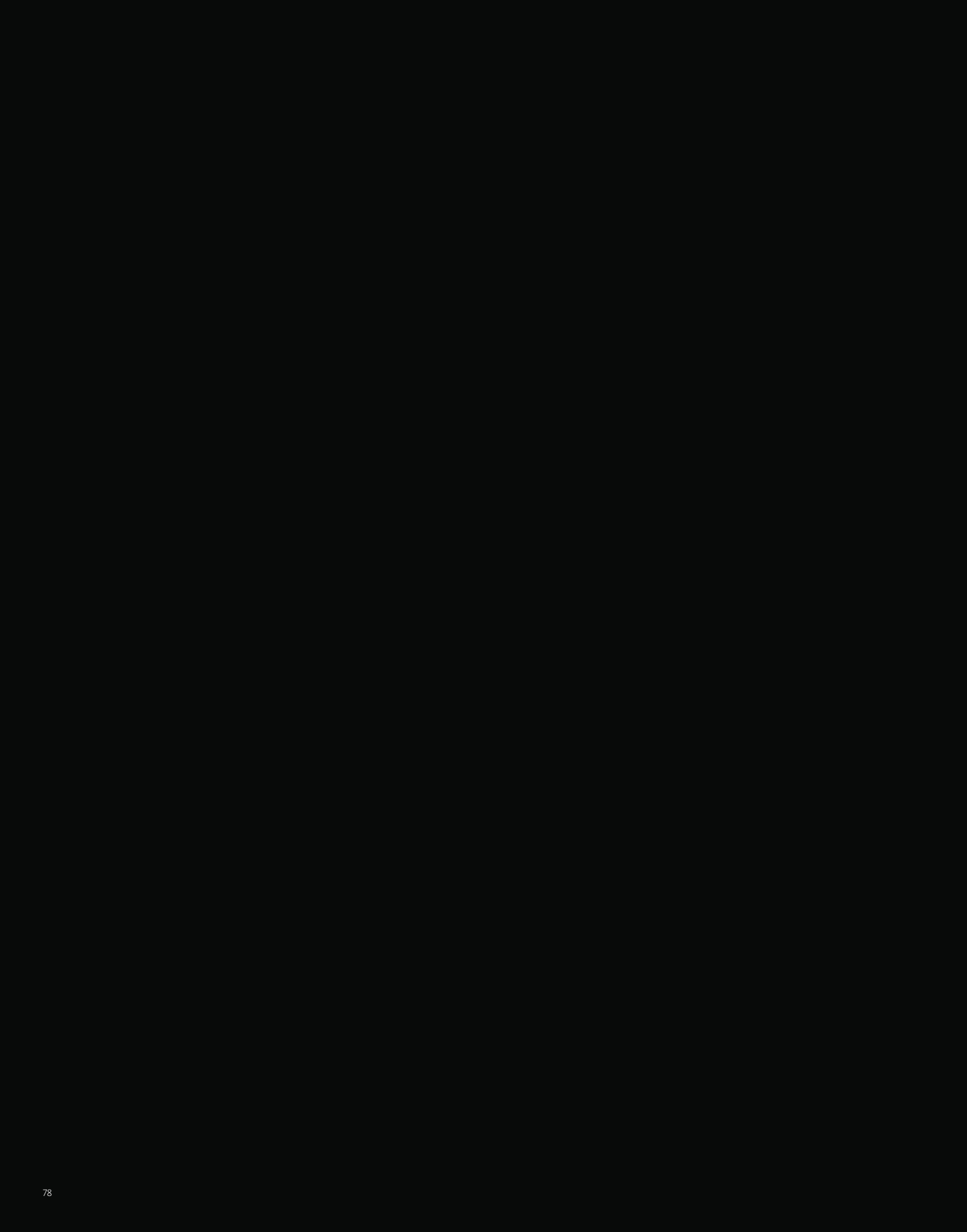

Lampada da tavolo con paralume in fibra di vetro disponibile in cinque differenti colori. Sorgente LED. Disponibile in altri colori a richiesta.



Table lamp with shade in fibre-glass: available in five different colors. On request any color available. With LED.

Tischleuchte mit Lampenschirm aus Glasfaserstoff lackiert. Auf Wunsch auch in weiteren Ausführungen lieferbar. Mit LED.

Lampe de table avec diffuseur créée en fibre de verre laquée en cinq finitions. Sur demande disponible dans toutes les couleurs. Avec LED.

Ola / Tavolo Piccola LED / Table desk / Table / Tischleuchte

OLA / Design Enrico Franzolini

OLA Tavolo Piccola		Appoggio / Table desk	
MISURE / DIMENSIONS			
CM.	INCHES	SORGENTI LUMINOSE / LIGHT SOURCES	
20,5ø x 13H	8ø x 5H	LED	
		5W 	
		LED INCLUSO / LED INCLUDED	
		CERTIFICATIONS	
COLORI / COLOURS		V  IP 20	
09AP20L2	Fibra di vetro Bianca / White Fibreglass		
09AP20L3	Fibra di vetro Rosso / Red Fibreglass		
09AP20L5	Fibra di vetro Arancio / Orange Fibreglass		
09AP20L6	Fibra di vetro Oro / Gold Fibreglass		
09AP20L7	Fibra di vetro Argento / Silver Fibreglass		

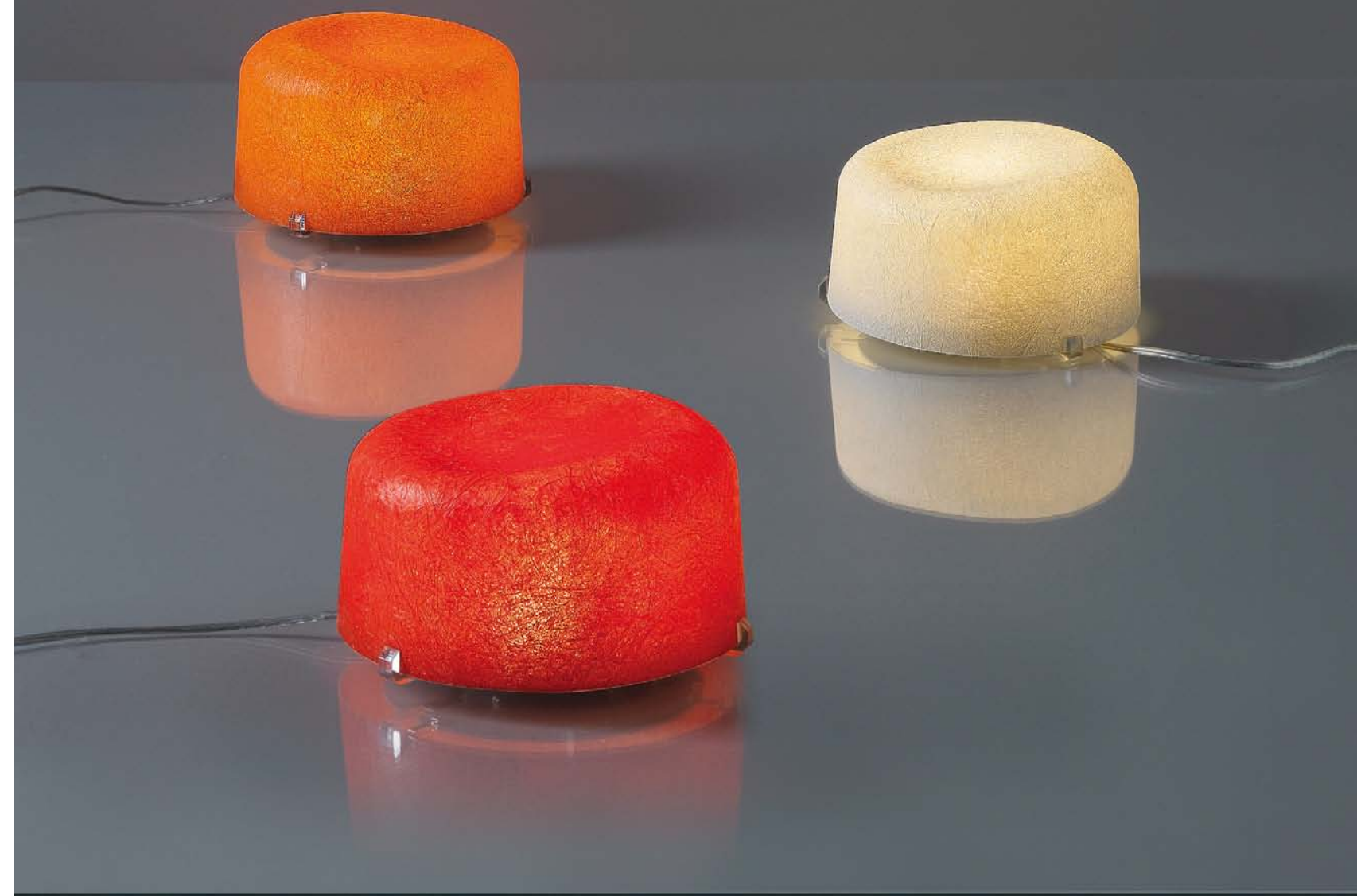
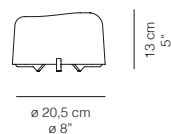

LED





Lampada da tavolo con paralume in fibra di vetro disponibile in cinque differenti colori. Stelo in metallo verniciato antracite. Disponibile in altri colori a richiesta.



Table lamp with shade in fibre-glass: available in five different colors. Base in anthracite painted metal. On request any color available.

Lampe de table avec diffuseur créée en fibre de verre laquée en cinq finitions base en metal anthracite. Sur demande disponible dans toutes les couleurs.

Tischleuchte mit Lampenschirm aus Glasfaserstoff lackiert. Die Stütze aus Metall Anthrazit lackiert. Auf Wunsch auch in weiteren Ausführungen lieferbar.

Ola / Tavolo Grande / Table / Table / Tischleuchte

OLA / Design Enrico Franzolini

OLA Tavolo Grande		Tavolo / Table		SORGENTI LUMINOSE / LIGHT SOURCES	
MISURE / DIMENSIONS					
CM.	INCHES			FLUO	LED
33ø x 21-53H	13ø x 8,26-21H	1x20W E27		1x10W E27	
COLORI / COLOURS				CERTIFICATIONS	
09TV32F2	Fibra di vetro Bianca / White Fibreglass			V CE IP 20 	
09TV32F3	Fibra di vetro Rosso / Red Fibreglass				
09TV32F5	Fibra di vetro Arancio / Orange Fibreglass				
09TV32F6	Fibra di vetro Oro / Gold Fibreglass				
09TV32F7	Fibra di vetro Argento / Silver Fibreglass				

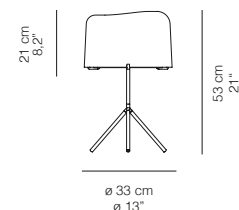

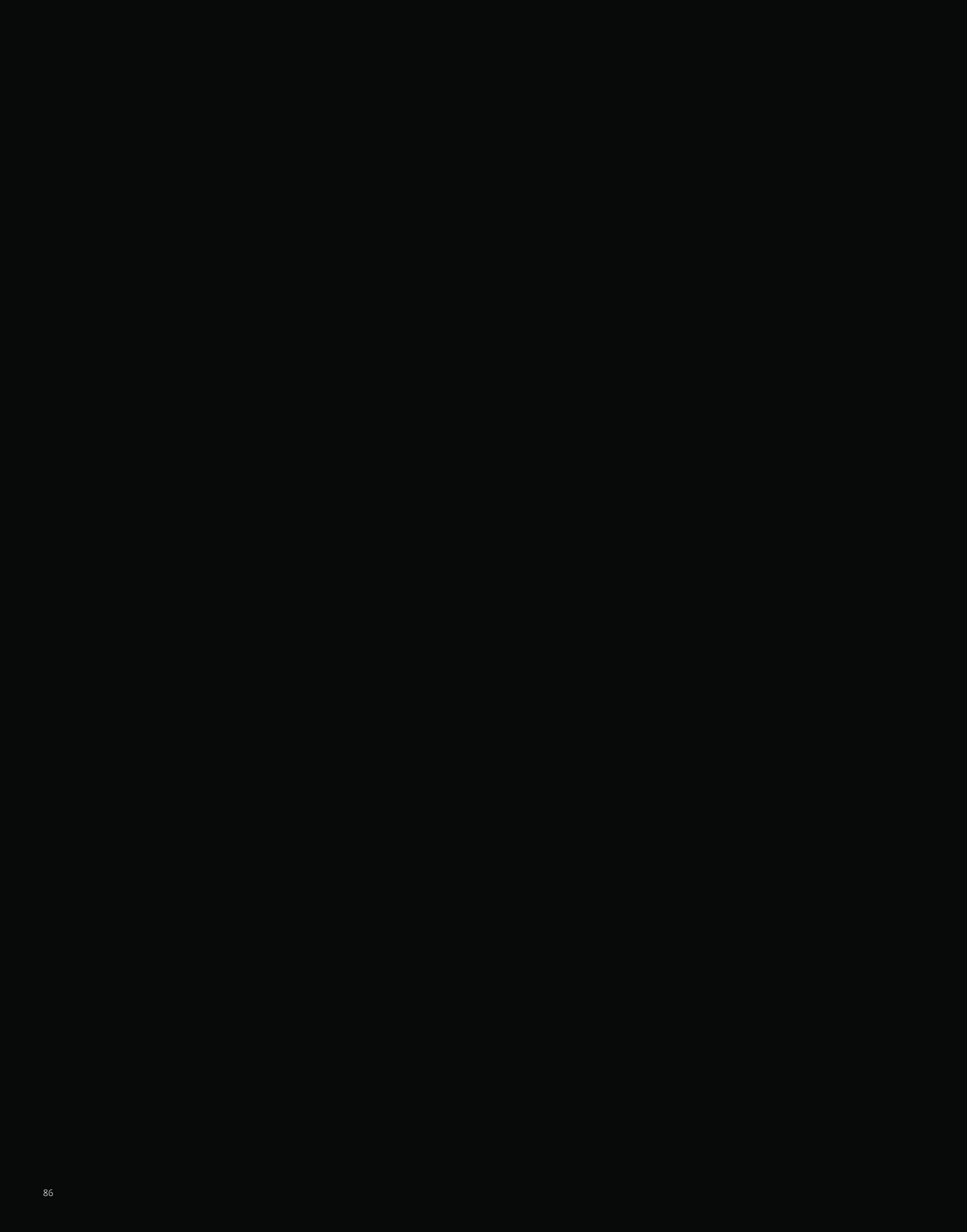

Lampada sospensione con paralume in fibra di vetro disponibile in cinque differenti colori. Disponibile in altri colori a richiesta.

Suspended lamp with shade in fibreglass: available in five different colors. On request any color available.

Suspension avec diffuseur créée en fibre de verre laquée en cinq finitions. Sur demande disponible dans toutes les couleurs.

Pendelleuchte mit Lampenschirm aus Glasfaserstoff lackiert. Auf Wunsch auch in weiteren Ausführungen lieferbar.

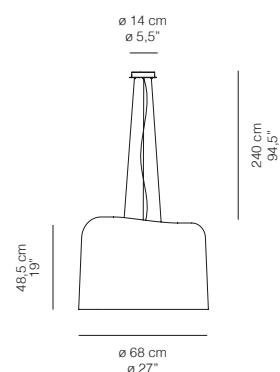

OLA / Design Enrico Franzolini

OLA	Sospensione / Suspended		SORGENTI LUMINOSE / LIGHT SOURCES	
	MISURE / DIMENSIONS			
	CM.	INCHES	FLUO	LED
	68ø x 48,5-240H	27ø x 19-94,5H	3x33W E27	3x16W E27
	COLORI / COLOURS		CERTIFICATIONS	
09SP68F2	Fibra di vetro Bianca / White Fibreglass		V IP 20	
09SP68F3	Fibra di vetro Rosso / Red Fibreglass			
09SP68F5	Fibra di vetro Arancio / Orange Fibreglass			
09SP68F6	Fibra di vetro Oro / Gold Fibreglass			
09SP68F7	Fibra di vetro Argento / Silver Fibreglass			
	OPZIONI / OPTIONS			
5MT	Sospensione cablaggio lunghezza cavi mt. 5,00 / Suspended with longer cables mt. 5,00			
09SPDIFF	Diffusore in metacrilato opalino / Diffuser in opaline methacrylate.			





Lampada sospensione con paralume in fibra di vetro disponibile in cinque differenti colori. Disponibile in altri colori a richiesta.

Suspended lamp with shade in fibreglass: available in five different colors. On request any color available.

Pendelleuchte mit Lampenschirm aus Glasfaserstoff lackiert. Auf Wunsch auch in weiteren Ausführungen lieferbar.

Suspension avec diffuseur créée en fibre de verre laquée en cinq finitions. Sur demande disponible dans toutes les couleurs.

Ola Fly / Sospensione / Suspended / Suspension / Pendelleuchte

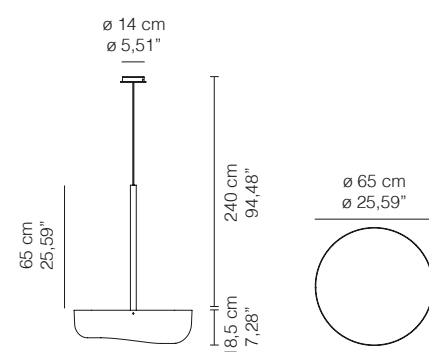

OLA Fly / Design Enrico Franzolini

Sospensione / Suspended

MISURE / DIMENSIONS

CM.	INCHES
65ø x 18,5-240H	25,59ø x 7,28-94,48H

SORGENTI LUMINOSE / LIGHT SOURCES

FLUO	LED
3x32W E27	3x16W E27

COLORI / COLOURS

09SP65F2	Fibra di vetro Bianca / White Fibreglass
09SP65F3	Fibra di vetro Rosso / Red Fibreglass
09SP65F5	Fibra di vetro Arancio / Orange Fibreglass
09SP65F6	Fibra di vetro Oro / Gold Fibreglass
09SP65F7	Fibra di vetro Argento / Silver Fibreglass

CERTIFICATIONS

OPZIONI / OPTIONS

5MT	Sospensione cablaggio lunghezza cavi mt. 5,00 / Suspended with longer cables mt. 5,00
09SPDIFL	Schermo superiore in metacrilato / Methacrylate top screen



OLA Slim /

Design Enrico Franzolini



Lampada che può essere montata da parete oppure a soffitto. Il paralume in fibra di vetro in cinque differenti colori. Disponibile in altri colori a richiesta.

A wall or ceiling mounted lamp. Shade in fibreglass: available in five different colors. On request any color available.

Lampe qui peut être montée sur un mur ou un plafond. Diffuseur créé en fibre de verre laquée en cinq finitions. Sur demande disponible dans toutes les couleurs.

Lampe, die als Wand- oder Deckenleuchte montiert werden kann. Lampenschirm aus Glasfaserstoff lackiert. Auf Wunsch auch in weiteren Ausführungen lieferbar.

Ola Slim/ Sospensione / Suspended / Suspension / Pendelleuchte

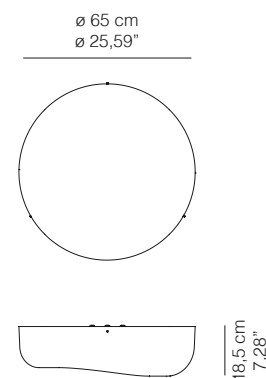

OLA Slim wall / ceiling / Design Enrico Franzolini

Sospensione / Suspended

MISURE / DIMENSIONS

CM.	INCHES
65ø x 18,5	25,59ø x 7,28

SORGENTI LUMINOSE / LIGHT SOURCES

FLUO	LED
3x32W E27	3x16W E27

COLORI / COLOURS

09PA65F2	Fibra di vetro Bianca / White Fibreglass
09PA65F3	Fibra di vetro Rosso / Red Fibreglass
09PA65F5	Fibra di vetro Arancio / Orange Fibreglass
09PA65F6	Fibra di vetro Oro / Gold Fibreglass
09PA65F7	Fibra di vetro Argento / Silver Fibreglass

CERTIFICATIONS

09PA65F2

09PA65F3

09PA65F5

09PA65F6

09PA65F7



Ola Slim/ Parete / Wall-mounted / Applique / Wandleuchte

Con Elios il designer Enrico Franzolini continua la sperimentazione ed il percorso di ricerca su come la luce, la forma ed il materiale possano intrecciarsi per ottenere oggetti, emozioni ed atmosfere particolari che ci accompagnino nei momenti della nostra vita quotidiana. Oro ed argento sono le nuove colorazioni del paralume in fibra di vetro che si uniscono a quelle più tradizionali quali il bianco e l'arancio. La sorgente scelta è il LED dimmerabile, molto performante ed idoneo ad illuminare spazi ampi con un bassissimo consumo.

Mit Elios setzt der Designer Enrico Franzolini seine Forschungen fort um nach Möglichkeiten zu suchen, wie Licht, Formen und Materialien zu neuen Leuchtoobjekten, Emotionen und Atmosphären die uns im täglichen Leben begleiten verbunden werden können. Gold und Silber sind die neuen Farben des Lampenschirmes aus Glasfaser die sich zu den traditionellen Farben wie Weiß und Orange hinzugesellen. Das sehr leistungsfähige, dimmbare LED Licht eignet sich zur Ausleuchtung von großen Räumen bei niedrigstem Energieverbrauch.

With Elios designer Enrico Franzolini continues his experimentation and research into how light, form and material can combine to create objects, emotions and special atmospheres that accompany us in every moment of our daily life. The fibreglass lampshade is now available in gold and silver, together with the more traditional shades of white and orange. The high performance LED bulb has a dimmer and can light large spaces with low energy consumption.

Avec Elios, le designer Enrico Franzolini continue ses expériences et son parcours de recherche sur comment la lumière, la forme et le matériau peuvent s'entremêler pour obtenir des objets, des émotions et des atmosphères particulières qui nous accompagnent dans les moments de notre vie de tous les jours. L'or et l'argent, nouvelles colorations des abat-jour en fibre de verre, rejoignent celles plus traditionnelles comme le blanc et l'orange. La source lumineuse est une LED avec variateur, très performante et adaptée à l'éclairage des grands espaces avec une faible consommation.





Lampada da terra con paralume in fibra di vetro disponibile nelle colorazioni bianco, arancio, argento e oro. Base in metallo verniciato antracite; sorgente LED luce calda. Dimmerabile.

Floor lamp with shade in fibreglass available in white, orange, silver and gold finishes. Base in anthracite painted metal. Warm LED light source. Dimmable.

Lampadaire avec diffuseur en fibre de verre laquée en quatre finitions: blanc, orange, argent et or. Base en métal laqué anthracite. Source LED à lumière chaude. Avec variateur d'intensité.

Stehleuchte mit Metallgestell, Ausführung Anthrazit, und Leuchtschirm aus Glasfaser, in den Ausführungen weiß, orange, Silber und Gold verfügbar. Warmes LED-Licht. Dimmbar.

Elios / Terra / Floor / Lampadaire / Stehleuchte

ELIOS / Designed by Enrico Franzolini

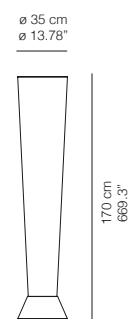

ELIOS	Terra / Floor			
	MISURE / DIMENSIONS		SORGENTI LUMINOSE / LIGHT SOURCES	with dimmer
	CM	INCHES	LED	
	35ø x 170H	13,78ø x 66,93H	95W - Lumen 10100 - 2700K	
			LED INCLUSO / LED INCLUDED	
	COLORI / COLOURS		CERTIFICATIONS	
25TR01NB	Fibra di vetro Bianca / White Fibreglass		V CE IP 20 CLASSE 1	
25TR01N5	Fibra di vetro Arancio / Orange Fibreglass			
25TR01NA	Fibra di vetro Argento / Silver Fibreglass			
25TR01NG	Fibra di vetro Oro / Gold Fibreglass			

LED

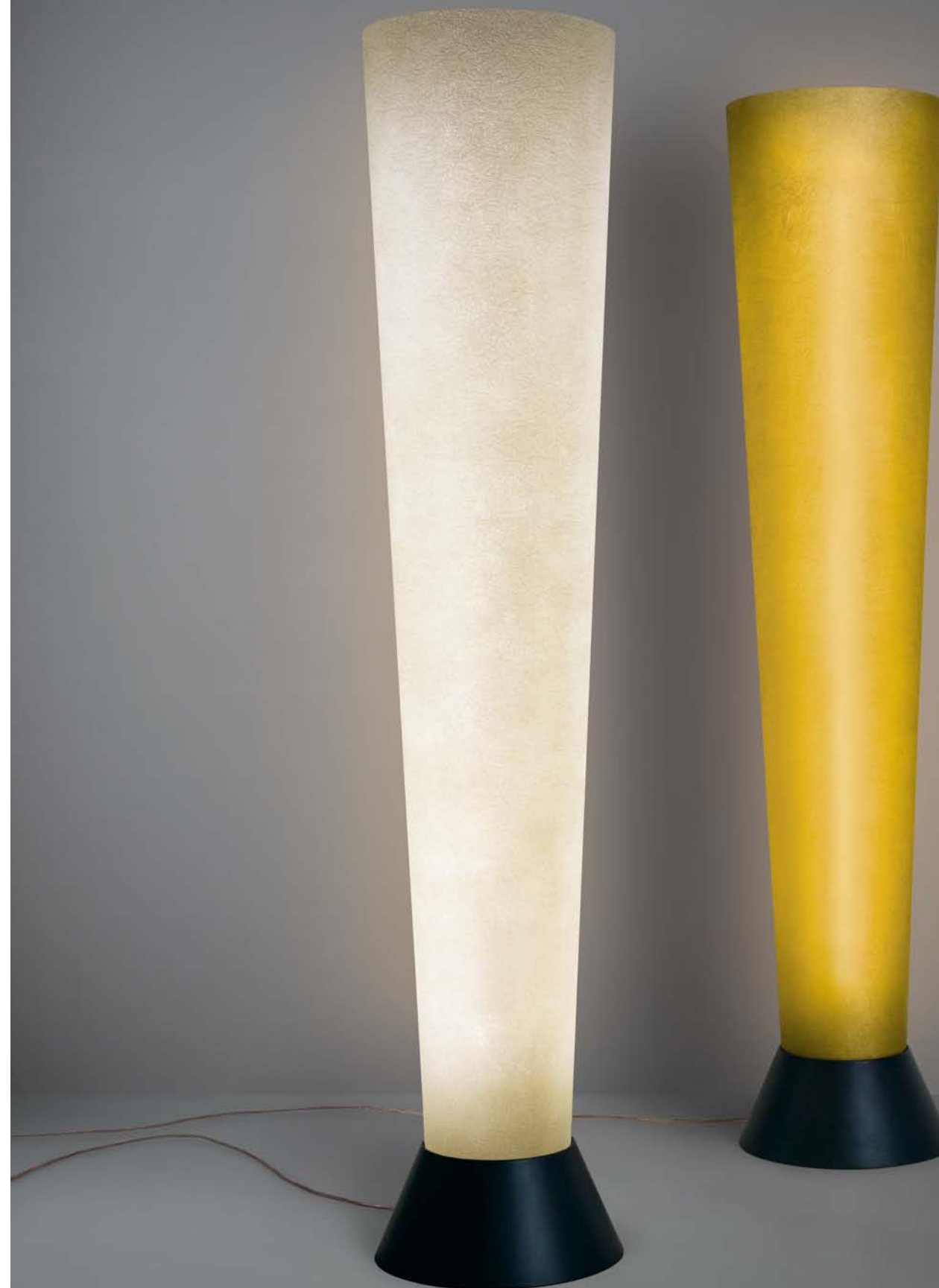

BABEL /

Design Fabio Flora

Da Babele nasce la nostra società.
Babele è la nostra società.
Suo simbolo, della sua genesi
e sopravvivenza, una torre mai
terminata, un tronco di cono che sale
a spirale. Oggi la torre è collassata
(la spirale non sale soltanto,
sale e scende) eppure c'è ancora;
è in equilibrio precario ed è alimentata
da una luce interna.

Our society was born from
Babele. Babele is our society.
A symbol of its genesis and
survival, a tower which was
never finished, a cone log that
rises like a spiral. Today the
tower is collapsed (the spiral
does not only rise, but rises and
falls) nevertheless it still exists;
its precarious equilibrium is
nourished from an inner light.

Notre société est née de Babel.
Babel symbolise notre société.
Un symbole de sa genèse, de
sa survie, une tour qui n'en finit
pas, un cône qui progresse en
spirale.

Unsere Gesellschaft entspringt
dem Turm zu Babel. Babel
ist unsere Gesellschaft. Sein
Symbol, seine Entstehung und
Überleben, ein nie fertiggestell-
ter Turm, Stumpf einer eines
spiralförmigen Kegels. Heute ist
der Turm eingestürzt, aber es
gibt ihn immer noch: er bleibt
in einem labilen Gleichgewicht
und wird von einem inneren
Licht angetrieben.





Lampada da terra con paralume in tessuto Honeycomb in colore bianco o nero. Treppiede in metallo verniciato bianco.

Floor lamp with shade in Honeycomb canvas fabric, in white or black. Tripod in white-painted metal.

Lampadaire avec abat-jour en tissu Honeycomb en couleurs blanc ou noir. Trépied en métal blanc.

Stehleuchte mit Lampenschirm aus Stoff-Honigwaben Weiß oder Schwarz. Gestell aus Metall weiß lackiert.

Babel / Terra / Floor / Lampadaire / Stehleuchte

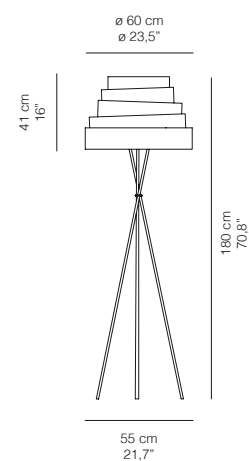

BABEL / Design Fabio Flora

BABEL	Terra / Floor		SORGENTI LUMINOSE / LIGHT SOURCES	
	MISURE / DIMENSIONS		FLUO	
	CM.	INCHES	LED	
	60ø x 41-180H	23,5ø x 16-70,8H	3x27W E27	3x16W E27
	COLORI / COLOURS		CERTIFICATIONS	
10TRWH01	Tessuto Honeycomb Bianco / White Honeycomb Canvas		□ ▽ CE IP 20	
10TRBK02	Tessuto Honeycomb Nero / Black Honeycomb Canvas			
	OPZIONI / OPTIONS			
DITR	Dimmer			

10TRBK02



10TRWH01

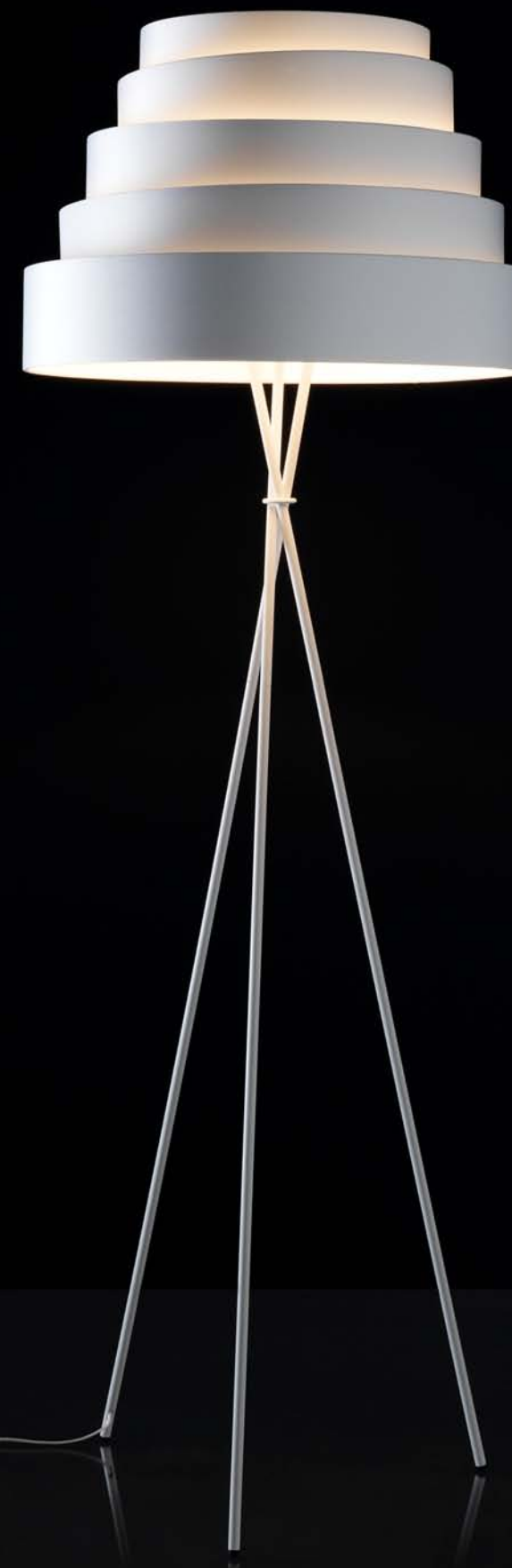



Lampada da sospensione con paralume in tessuto Honeycomb in colore bianco o nero. Supporto in metallo verniciato bianco. Diffusore opalino.

Suspended lamp with shade in Honeycomb canvas fabric, in white or black. Ceiling fitting in white-painted metal. With opaline diffuser.

Suspension avec abat-jour en tissu Honeycomb en couleurs blanc ou noir. Support en métal blanc. Avec diffuseur opalin.

Pendelleuchte mit Lampenschirm aus Stoff-Honigwaben Weiß oder Schwarz. Gestell aus Metall weiß lackiert. Blendschutz Opalen.

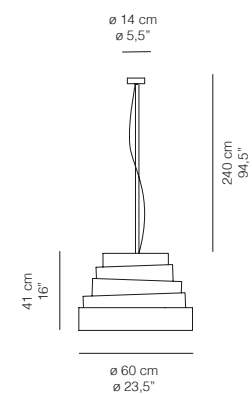

BABEL / Design Fabio Flora

BABEL	Terra / Floor				
	MISURE / DIMENSIONS			SORGENTI LUMINOSE / LIGHT SOURCES	
	CM.	INCHES	FLUO	LED	
	60ø x 41-240H	23,5ø x 16-94,5H	3x23W E27	3x16W E27	
	COLORI / COLOURS			CERTIFICATIONS	
10SPWH01	Tessuto Honeycomb Bianco / White Honeycomb Canvas				
10SPBK02	Tessuto Honeycomb Nero / Black Honeycomb Canvas				
	OPZIONI / OPTIONS				
5MT	Sospensione cablaggio lunghezza cavi mt. 5,00 / Suspended with longer cables mt. 5,00				



10SPWH01

10SPBK02



AFRA /

Design Enrico Franzolini

Una quasi sfera di vetro soffiato con una scanalatura mediana ad accogliere una cuffia tessuta a mano. Texture tessili uniche che filtrano la luce in modo sempre diverso. L'esaltazione del fatto a mano.

A nearly sphere of blown glass with a median groove which holds a hand crocheted cap. Crocheted in an unique weave texture that always filters the light in various ways.

Une quasi sphère en verre soufflé avec une élégante rainure sur laquelle vient se fixer une coiffe au crochet. Tissage à la texture unique qui vient filtrer la lumière dans la partie supérieure.

Fast schon eine perfekte Kugel aus mundgeblasenem Glas mit einer umlaufenden Rille, die eine handgewebte Haube aufnimmt. Einzigartige Textiltexturen, die das Licht in immer anderer Weise filtern: die Vollendung der Handwerkskunst.

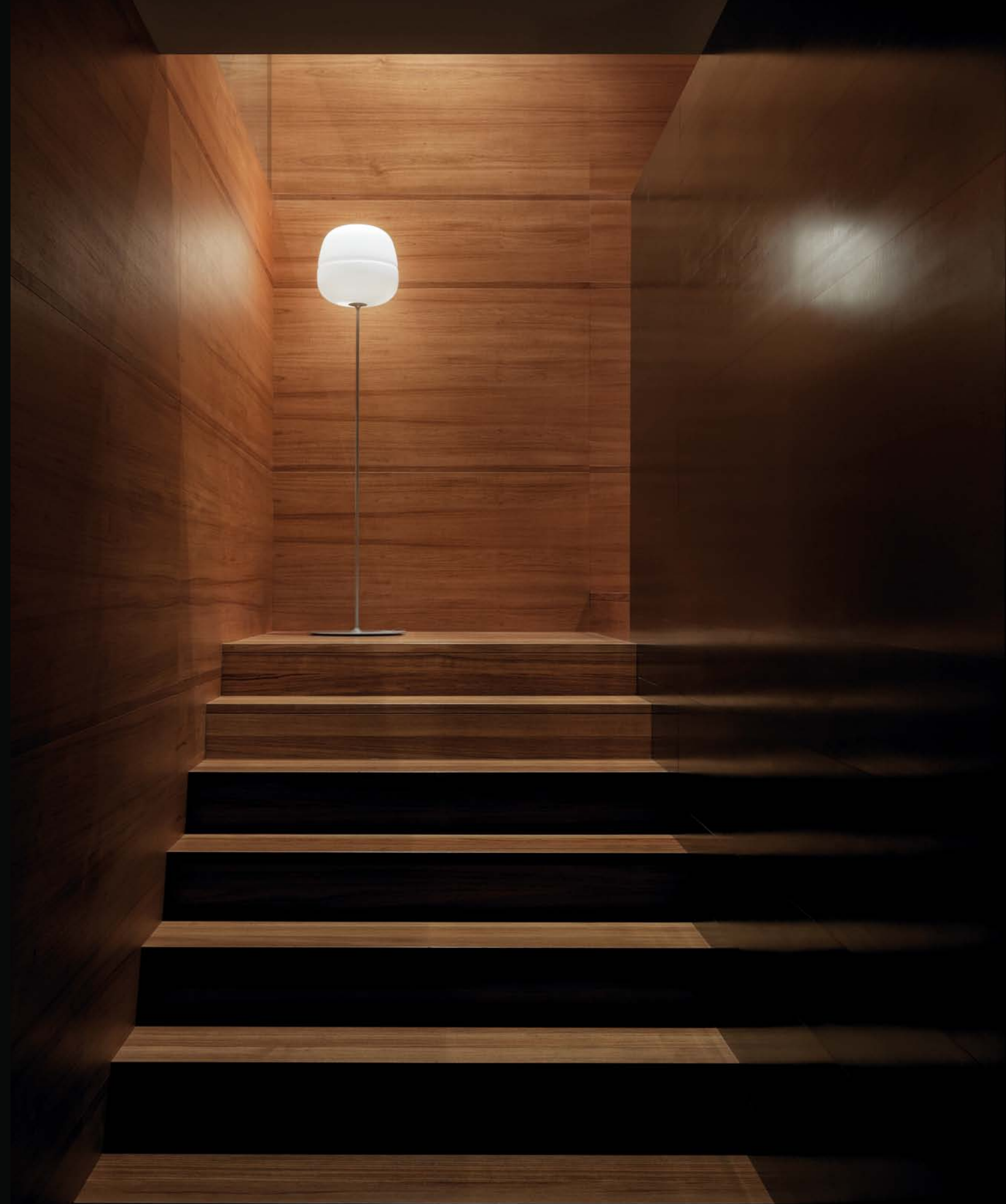

Lampada da terra a luce diffusa.
Diffusore in vetro opalino, soffiato
a bocca, con finitura esterna acidata,
bianca. Base in alluminio verniciato
grigio chiaro. Cuffia decorativa
opzionale nei colori: nero o beige.

Floor lamp providing diffused
light. Diffuser consisting of an
externally acid-etched hand
blown, flashed opaline
white glass Base in aluminium
painted light grey. On request,
decorative cap in black or beige.

Lampadaire à lumière diffuse.
Diffuseur en verre opalin,
soufflé à la bouche, avec
finition extérieure acide en color
blanc. Base en alu gris clair.
Coiffe décorative optionnelle
en couleurs noir ou beige.

Stehleuchte mit dem Streulicht.
Blendschutz aus geblasen Glas
Opalen mit der äußere geätzte
Ausführung, Farbe Weiß,
Grau und Bernstein. Stütze aus
Aluminium hell Grau lackiert.
Dekoratives Netz in schwarz
oder beige.

Afra / Terra / Floor / Lampadaire / Stehleuchte

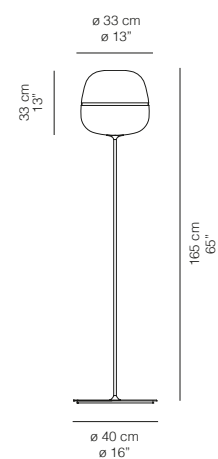

AFRA / Design Enrico Franzolini

AFRA	Terra / Floor		SORGENTI LUMINOSE / LIGHT SOURCES	
	MISURE / DIMENSIONS		FLUO	
	CM.	INCHES	LED	
13TRWH01	40-33ø x 165H	16-13ø x 65H	1x23W E27	1x16W E27
	COLORI / COLOURS		CERTIFICATIONS	
	Vetro acidato bianco / White acid-etched glass			
	OPZIONI / OPTIONS			
13NETWH	Cuffia Beige / Beige cap			
13NETBK	Cuffia Nera / Black cap			
D1TR	Dimmer			

13TRWH01



13NETWH

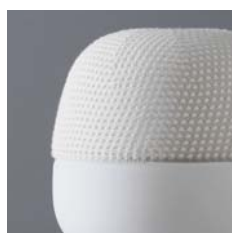

13NETBK

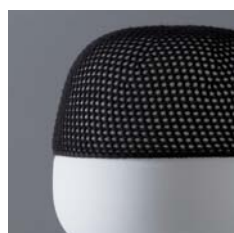



Lampada da tavolo a luce diffusa.
Diffusore in vetro opalino,
soffiato a bocca, con finitura esterna
acidata, bianca. Base in alluminio
verniciato grigio chiaro.
Cuffia decorativa opzionale nei colori:
nero o beige.

Table lamp providing diffused light.
Diffuser consisting of an externally
acid-etched hand blown, flashed
opaline glass available in white.
Steel suspension cable.
Ceiling fitting painted light grey.
On request, decorative cap in black
or beige.

Tischleuchte mit Streulicht.
Tischleuchte mit satiniertem
Lampenschirm aus
mundgeblasenem weißem Glas.
Stütze aus Alu hellgrau lackiert.
Optional mit dekorativer
Netzhaube in schwarz oder beige.

Lampe de table à lumière diffuse.
Diffuseur en verre opalin, soufflé
à la bouche, avec finition extérieure
acide en couleurs blanc.
Câble de suspension en acier.
Plafond en métal laqué en gris clair.
Coiffe décorative optionnelle en
couleurs noir ou beige.

Afra / Tavolo / Table / Table / Tischleuchte

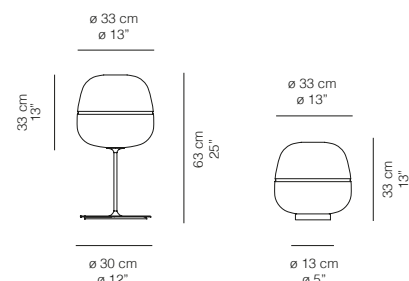

AFRA / Design Enrico Franzolini

AFRA	Tavolo / Table		SORGENTI LUMINOSE / LIGHT SOURCES		CERTIFICATIONS
	MISURE / DIMENSIONS		FLUO		<input type="checkbox"/> <input type="checkbox"/> <input type="checkbox"/> CE IP 20
	CM.	INCHES	LED		
13TVWH01	33ø x 63H	13ø x 25H	1x23W E27	1x16W E27	
	COLORI / COLOURS				
	Vetro acidato bianco / White acid-etched glass				
AFRA	Da appoggio / Table desk		SORGENTI LUMINOSE / LIGHT SOURCES		CERTIFICATIONS
	MISURE / DIMENSIONS		FLUO		<input type="checkbox"/> <input type="checkbox"/> <input type="checkbox"/> CE IP 20
	CM.	INCHES	LED		
13APWH01	33 ø x 33H	13 ø x 13H	1x23W E27	1x16W E27	
	COLORI / COLOURS				
	Vetro acidato Bianco / White acid-etched glass				
	OPZIONI / OPTIONS				
13NETWH	Cuffia Beige / Beige cap				
13NETBK	Cuffia Nera / Black cap				
DITV	Dimmer				

13TVWH01 / 13APWH01

13NETBK

13NETWH

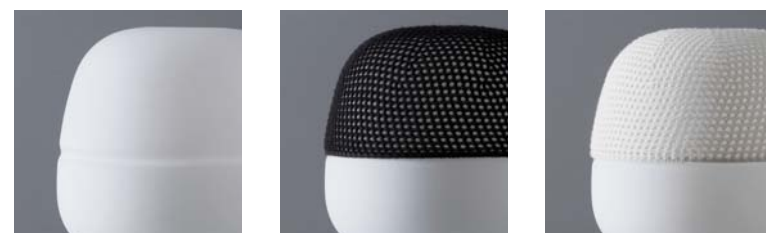

Afra / Da appoggio / Table desk / Table / Standleuchte

Lampada da sospensione a luce diffusa. Diffusore in vetro opalino, soffiato a bocca, con finitura esterna acidata, bianca.
Base in alluminio verniciato grigio chiaro. Cuffia decorativa opzionale nei colori: nero o beige.

Suspended lamp providing diffused light. Diffuser consisting of an externally acid-etched hand blown, flashed opaline glass available in white.
Steel suspension cable.
Ceiling fitting painted light grey.
On request, decorative cap in black or beige.

Suspension à lumière diffuse. Diffuseur en verre opalin, soufflé à la bouche, avec finition extérieure acide en couleurs blanc. Câble de suspension en acier. Plafond en métal laqué en gris clair. Coiffe décorative optionnelle en couleurs noir ou beige.

Pendelleuchte mit satiniertem Lampenschirm aus mundgeblasenem weißem Glas. Metallelement aus Alu hellgrau lackiert. Optional mit dekorativer Netzhaube in schwarz oder beige.

Afra / Sospensione / Suspended / Suspension / Pendelleuchte

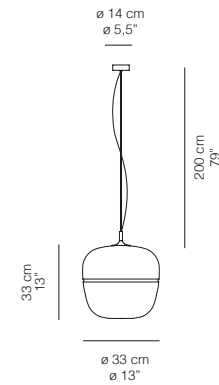

AFRA / Design Enrico Franzolini

AFRA	Sospensione / Suspended		SORGENTI LUMINOSE / LIGHT SOURCES		CERTIFICATIONS
	MISURE / DIMENSIONS				
	CM.	INCHES	FLUO	LED	
13SPWH01	33ø x 33-200H	13ø x 13-79H	1x23W E27	1x16W E27	
	COLORI / COLOURS				
	Vetro acidato Bianco / White acid-etched glass				
	OPZIONI / OPTIONS				
13NETWH	Cuffia Beige / Beige cap				
13NETBK	Cuffia Nera / Black cap				
5MT	Sospensione cablaggio lunghezza cavi mt. 5,00 / Suspended with longer cables mt. 5,00				



13SPWH01



13NETWH



13NETBK



PEGGY /

Design Enrico Franzolini

Collezione tavolo e terra caratterizzata dalla forma sinuosa e dinamica del paralume nelle versioni: juta naturale e fibra di vetro bianca o nera. Base in metallo cromato.

Table and floor collection with a sleek and streamlined shade in fibreglass white or black and jute natural fabric available. Base in chromed metal.

Lampe et Lampadaire caractérisés par la forme sinueuse et dynamique du l'abat-jour. Disponible en fibre de verre blanc ou noir ou en toile de jute naturelle. Base en métal chromé.

Kollektion von Tisch- und Bodenlampen, der elegant geschwungene Schirm der Peggy ist in folgenden Versionen verfügbar: natürliche Jute und Glasfaser in weiß oder schwarz. Das passende Gestell aus verchromtem Metall.



Lampada da tavolo dalla forma sinuosa e dinamica del paralume. Disponibile in fibra di vetro bianca o nera dalle sfumature grigio chiaro e Jute naturale, con base in metallo cromato.

Table lamp with a sleek and streamlined shade. Available in fibreglass white, black with light grey hues or Jute natural with base in chromed metal.

Tischleuchte mit einem elegant geschwungenen Lampenschirm. Erhältlich in Glasfaser weiß oder schwarz mit Schattierungen in hellgrau oder in Jute natur.

Lampe de table avec un abat-jour de forme sinueuse et dynamique. Disponible en fibre de verre blanche o en noir avec des nuances gris clair et Jute naturelle avec base en métal chromé.

Peggy / Tavolo / Table / Table / Tischleuchte

PEGGY / Design Enrico Franzolini

PEGGY	Tavolo / Table		SORGENTI LUMINOSE / LIGHT SOURCES	
	MISURE / DIMENSIONS			
	CM.	INCHES	FLUO	
	45 x 28 x 32-71H	17,7 x 11 x 12,5-28H	LED	
			1x20W E27	1x10W E27
	COLORI / COLOURS		CERTIFICATIONS	
07TVWH01	Fibra di vetro Bianco / White Fibreglass		CE IP 20	
07TVBK01	Fibra di vetro Nero / Black Fibreglass			
07TVJU01	Juta naturale / Jute natural			
DITV	Dimmer			

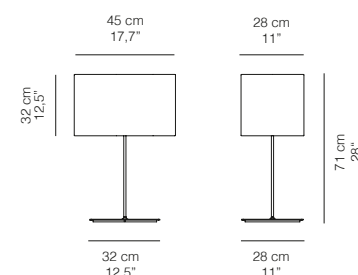

07TVBK01

07TVWH01

07TVJU01



Lampada da terra dalla forma sinuosa e dinamica del paralume. Disponibile in fibra di vetro bianca, nera dalle sfumature grigio chiaro e Juta naturale, con base in metallo cromato.

Floor lamp with a sleek and streamlined shade. Available in fibreglass white, black with light grey hues or Jute natural, with base in chromed metal.

Lampadaire avec un abat-jour de forme sinueuse et dynamique. Disponible en fibre de verre blanche o en noir avec des nuances gris clair et Juta naturelle avec base en métal chromé.

Stehleuchte mit einem elegant geschwungenen Lampenschirm. Erhältlich in Glasfaser weiß oder schwarz mit Schattierungen in hellgrau oder in Jute natur.

Peggy / Terra / Floor / Lampadaire / Stehleuchte

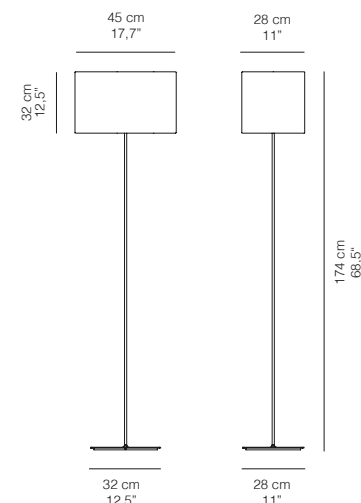

PEGGY / Design Enrico Franzolini

PEGGY	Terra / Floor		SORGENTI LUMINOSE / LIGHT SOURCES	
	MISURE / DIMENSIONS			
	CM.	INCHES	FLUO LED	
	45 x 28 x 32-174H	17,7 x 11 x 12,5-68,5H	1x20W E27 1x10W E27	
	COLORI / COLOURS		CERTIFICATIONS	
07TRWH01	Fibra di vetro Bianco / White Fibreglass		□ ▽ CE IP 20	
07TRBK01	Fibra di vetro Nero / Black Fibreglass			
07TRJU01	Juta naturale / Jute natural			
DITR	Dimmer			

07TRBK01



07TRWH01



07TRJU01



WARM /

Design Enrico Franzolini

Essere alla ricerca di geometrie morbide e sinuose, cercare qualcosa che esca dall'ombra. Trovare Warm, una lampada da interno ed esterno; la linea esalta il materiale e viceversa, come quando il diffusore in polietilene, in un gioco di trasparenze, si veste di una rete sensuale creando atmosfere suggestive. L'ispirazione e la tecnologia insieme per un risultato di luce calda ed avvolgente.

Searching for soft, sinuous shapes, looking for something that steps out from the shade. Discover Warm, a lamp for inside and outside, an evocative figure; the shape exalts the material and vice versa, like when the polyethylene spreader, playing with transparencies, puts on a sensual net creating suggestive atmospheres. Inspiration and technology together result in warm, embracing light.

A la recherche de formes douces et sinueuses, de quelque chose qui jaillit de l'ombre. Nous avons inventé WARM, une lampe pour l'intérieur ou l'extérieur, forme originale et objet technologique à la fois; la forme valorise les matières et vice versa; quand le diffuseur en polyéthylène jouant avec la transparence met un filet sensuel pour créer une atmosphère suggestive.

Auf der Suche nach weichen, geschwungenen Formen, nach etwas, das sich aus den Schatten löst. „Warm“ entdecken: eine Leuchte für Innen und Außen, die eine eindrucksvolle Form; das Design erhebt die Form des Materials und umgekehrt, der Diffusor aus Polyethylen mit spielt mit seinen Transparenzen, umgibt sich mit einem sinnlichen Netz das wunderbare suggestive Atmosphären schafft. Inspiration und Technologie kreieren ein warmes und fühlbar geschmeidiges Licht.





Lampada da terra con diffusore in polietilene bianco e base in metallo zincato verniciato in colore nero anche per utilizzo outdoor. A richiesta, rete tessile di copertura bianca o nera.

Floor lamp with white polyethylene shade and metallic base, painted black for outdoor use. On request, black or white net.

Lampadaire avec diffuseur en polyéthylène blanc et base en métal galvanisée laquée en noir pour utilisation à l'extérieur. Sur demande filet textile de couverture couleurs blanc ou noir.

Stehleuchte mit Blendschutz aus weißem Polyäthylen und Stütze aus schwarz verzinktem Metall. Auch für Outdoor geeignet. Auf Wunsch mit dekorativem weißen oder schwarzen Netz.

Warm / Terra / Floor / Lampadaire / Stehleuchte

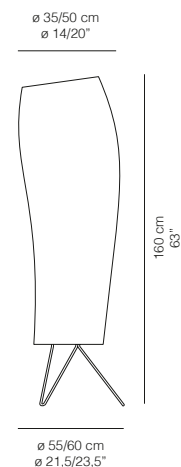

WARM / Design Enrico Franzolini

WARM INDOOR	Terra / Floor	SORGENTI LUMINOSE / LIGHT SOURCES		
	MISURE / DIMENSIONS	FLUO	LED	
	CM. INCHES	1x40W E27	1x16W E27	with dimmer
	35/50 - 55/60ø x 160H 14/20 - 21,5/23,5ø x 63H			CERTIFICATIONS
	COLORI / COLOURS			
08WAIN02	Polietilene bianco / White polyethylene			
	Dimmer incluso / Dimmer included			
WARM OUTDOOR	Terra / Floor	SORGENTI LUMINOSE / LIGHT SOURCES		
	MISURE / DIMENSIONS	FLUO	LED	
	CM. INCHES	1x40W E27	1x16W E27	CERTIFICATIONS
	35/50 - 55/60ø x 160H 14/20 - 21,5/23,5ø x 63H			
	COLORI / COLOURS			IP 44 con spina / with plug
08WAO01	Polietilene bianco / White polyethylene			
	OPZIONI / OPTIONS			
08WANETWH	Rete bianca / White net			
08WANETBK	Rete nera / Black net			



ESCAPE /

Design Serena Papait

Escape è una lampada che nasce con l'intento di sperimentare la dinamicità della luce in un contesto di staticità, di creare una sorta di vibrazione che si manifesta con la lettura di diversi livelli di luce. La lampada è composta da una serie di elementi perfettamente orizzontali e paralleli tra di loro, che rappresentano la volontà di ricercare mediante la forma un equilibrio e un ordine naturale.

Escape is a lamp that has been designed in the attempt to experience the dynamism of light in a context of stillness a kind of vibration that manifests with the diffusion of the light at different levels. The lamp is composed of a series of perfectly horizontal elements, parallel between them, that represent the will to search, by means of this shape, an equilibrium and natural order.

Escape est une lampe dessinée dans le but d'expérimenter le dynamisme d'une lumière statique, de créer une sorte de vibration qui permet de diffuser la lumière sur plusieurs niveaux. La lampe est composée d'une série d'éléments parfaitement horizontaux, tous parallèles, symbole de la recherche d'un équilibre et d'un ordre naturel.

Escape ist eine Leuchte, die mit der Absicht, das dynamische Licht in einer Umgebung der Stabilität zu studieren, erstellt wurde: das Ziel, eine Art von Vibration in verschiedenen Lichtebenen zu kreieren. Die Leuchte besteht aus einer Reihe von exakt horizontal und parallel zueinander angeordneten Elementen, die die Suche nach einer natürlichen Ordnung repräsentieren.



Lampada da terra composta da 6 elementi in alluminio verniciati bianco, disposti orizzontalmente ed in modo parallelo.

Floor lamp made up from 6 elements in white painted aluminium, horizontally arranged and parallel to each other.

Lampadaire composée de 6 éléments en alu laqués en blanc, disposés horizontalement et parallèlement entre eux.

Stehleuchte mit 6 Elementen aus Aluminium weiß lackiert gebaut, horizontal und parallel angeordnet.

Escape / Terra / Floor / Lampadaire / Stehleuchte

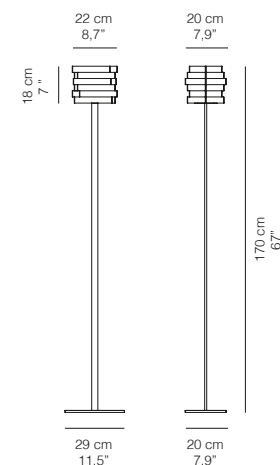

ESCAPE / Design Serena Papait

ESCAPE	Terra / Floor		SORGENTI LUMINOSE / LIGHT SOURCES		CERTIFICATIONS
	MISURE / DIMENSIONS		FLUO		
	CM.	INCHES	LED		
12TRO10W	29 x 20 x 18-170H	11,5 x 7,9 x 7-67H	2x20 E27	2x10W E27	
	COLORI / COLOURS				
	Metallo verniciato Bianco / White metal painted				
	OPZIONI / OPTIONS				
DITR	Dimmer				





Lampada da tavolo composta da 6 elementi in alluminio verniciati bianco, disposti orizzontalmente ed in modo parallelo.

Table lamp made up from 6 elements in white painted aluminium, horizontally arranged and parallel to each other.

Tischleuchte mit 6 Elementen aus Aluminium weiß lackiert gebaut, horizontal und parallel angeordnet.

Lampe de table composée de 6 éléments en alu laqués en blanc, disposés horizontalement et parallèlement entre eux.

Escape / Tavolo / Table / Table / Tischleuchte

ESCAPE / Design Serena Papait

ESCAPE	Tavoli / Table		SORGENTI LUMINOSE / LIGHT SOURCES	
	MISURE / DIMENSIONS		FLUO	LED
	CM.	INCHES	2x20 E27	2x10W E27
12TV010W	22 x 13 x 18-26H	8,7 x 5,1 x 7,1-10,2H		
	COLORI / COLOURS		CERTIFICATIONS	
	Metallo verniciato Bianco / White metal painted		CE IP 20	
	OPZIONI / OPTIONS			
DITR	Dimmer			

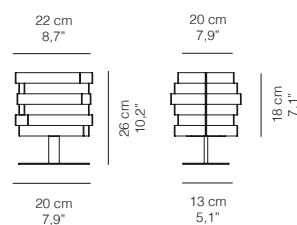



Lampada da sospensione composta da 5 elementi in alluminio verniciato bianco, disposti orizzontalmente ed in modo parallelo.
Diffusore in metacrilato opalino.

Suspended lamp made up with 5 elements in white painted aluminium, horizontally arranged and parallel to each other. Shade in opaline methacrylate.

Pendelleuchte mit 5 aus weiß lackiertem Aluminium horizontal und parallel angeordneten Elementen. Der Blendschutz ist aus satiniertem Acrylglas.

Suspension composée de 5 éléments en alu laqués en blanc, disposés horizontalement et parallèlement entre eux. Diffuseur en méthacrylate opalin.

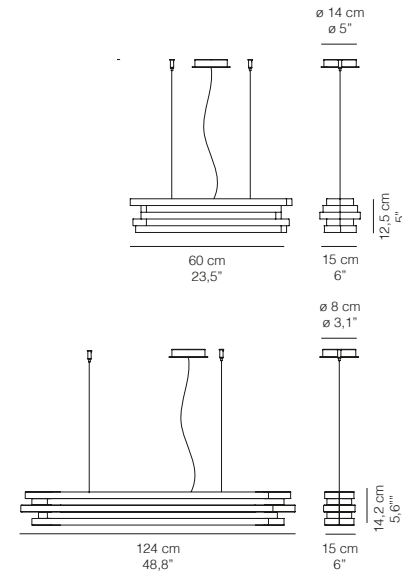

ESCAPE / Design Serena Papait

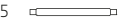
ESCAPE	Sospensione / Suspended		SORGENTI LUMINOSE / LIGHT SOURCES		CERTIFICATIONS
	MISURE / DIMENSIONS				
	CM.	INCHES	FLUO		
12SP06FW	60 x 15 x 12,5H	23,5 x 6 x 5H	2x20W-E27 		
12SPWH01	124 x 15 x 14,2H	48,8 x 6 x 5,6H	2x39W-T5 G5 	6200 Lumen	
	COLORI / COLOURS		CERTIFICATIONS		
	Alluminio verniciato Bianco / White painted aluminium		CE IP 20		
	OPZIONI / OPTIONS				
5MT	Sospensione cablaggio lunghezza cavi mt. 5,00 / Suspended with longer cables mt. 5,00				
DIMM	Dimmerabile DALI (12SPWH01) / Dimmable DALI (12SPWH01)				



ESCAPE 124 - 12SPWH01



ESCAPE 60 - 12SP06FW





Lampada da parete composta da elementi in alluminio verniciati bianco, disposti orizzontalmente ed in modo parallelo. Diffusore in metacrilato opalino.



Wall-mounted lamp made up from elements in white painted aluminium, horizontally arranged and parallel to each other. Shade in opaline methacrylate.

Applique composée de éléments en alu laqués en blanc, disposés horizontalement et parallèlement entre eux. Diffuseur en méthacrylate opalin.

Wandleuchte mit 5 aus weiß lackiertem Aluminium horizontal und parallel angeordneten Elementen. Der Blendschutz ist aus satiniertem Acrylglas.

Escape 78-44 / Parete / Wall-mounted / Applique / Wandleuchte

ESCAPE / Design Serena Papait

ESCAPE	Parete/ Wall		SORGENTI LUMINOSE / LIGHT SOURCES		CERTIFICATIONS
	MISURE / DIMENSIONS		FLUO		
	CM.	INCHES			
12PAWH44	44 x 10,5 x 15H	17 x 4 x 6H	2x11W E14 		CE IP 20 
12PAWH78	78 x 11,5 x 17H	31 x 4,5 x 7H	2x24W-T5 G5 		CE IP 20
	COLORI / COLOURS				
	Alluminio verniciato Bianco / White painted aluminium				
	OPZIONI / OPTIONS				
DIMM	Dimmerabile DALI (12PAWH78) / Dimmable DALI (12PAWH78)				

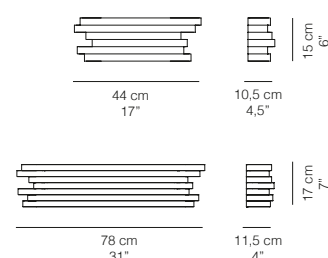

ESCAPE 78 - 12PAWH78



ESCAPE 44 - 12PAWH44



Lampada da parete composta da 3 elementi in alluminio verniciati bianco, disposti orizzontalmente ed in modo parallelo. Diffusore in metacrilato opalino. Disponibile con sorgente LED o fluorescente. Dimmerabili su richiesta.

Wall-mounted lamp made up from 3 elements in white painted aluminium, horizontally arranged and parallel to each other. Shade in opaline methacrylate. Available with LED technology or fluorescent bulb. Dimmerable DALI on request.

Wandleuchte mit 3 aus weiß lackiertem Aluminium horizontal und parallel angeordneten Elementen. Der Blendschutz ist aus satiniertem Acrylglas. Mit LED oder Leuchtstoffröhre erhältlich. Auf Anfrage auch Dimmer DALI.

Applique composée de 3 éléments en alu laqués en blanc, disposés horizontalement et parallèlement entre eux. Diffuseur en méthacrylate opalin. Disponible avec source LED ou FLUO. Niveaux d'éclairage réglables - DALI à la demande.

Escape 50-80-110 / Parete / Wall-mounted / Applique / Wandleuchte

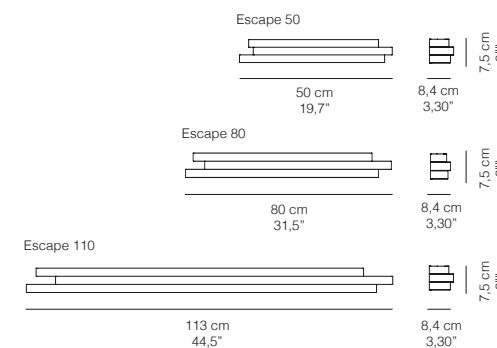

ESCAPE / Design Serena Papait

Parete/ Wall		SORGENTI LUMINOSE / LIGHT SOURCES		
MISURE / DIMENSIONS		FLUO	LED	
ESCAPE 50				
12PA05LW (MW)	50 x 8,4 x 7,5H	19,7 x 3,30 x 3H	12W Lumen 1300 - 2700K	☉☉☉☉ (MW) Dimmer DALI
ESCAPE 80				
12PA08LW (MW)	80 x 8,4 x 7,5H	31,5 x 3,30 x 3H	24W Lumen 2600 - 2700K	☉☉☉☉ (MW) Dimmer DALI
12PA08FW (GW)	80 x 8,4 x 7,5H	31,5 x 3,30 x 3H	1x24W-T5 G5	☉☉☉☉ (GW) Dimmer DALI
ESCAPE 110				
12PA11LW (MW)	113 x 8,4 x 7,5H	44,5 x 3,30 x 3H	36W Lumen 3900 - 2700K	☉☉☉☉ (MW) Dimmer DALI
12PA11FW (GW)	113 x 8,4 x 7,5H	44,5 x 3,30 x 3H	1x39W-T5 G5	☉☉☉☉ (GW) Dimmer DALI
		LED INCLUSO / LED INCLUDED		
COLORI / COLOURS		Alluminio verniciato Bianco / White painted aluminium		CERTIFICATIONS
OPZIONI / OPTIONS		LED 3000K su richiesta / LED 3000K on demand		CE IP 20

LED

ESCAPE 110 - 12PA11LW (MW) / 12PA11FW (GW)
ESCAPE 80 - 12PA08LW (MW) / 12PA08FW (GW)

ESCAPE 50 - 12PA05LW (MW)



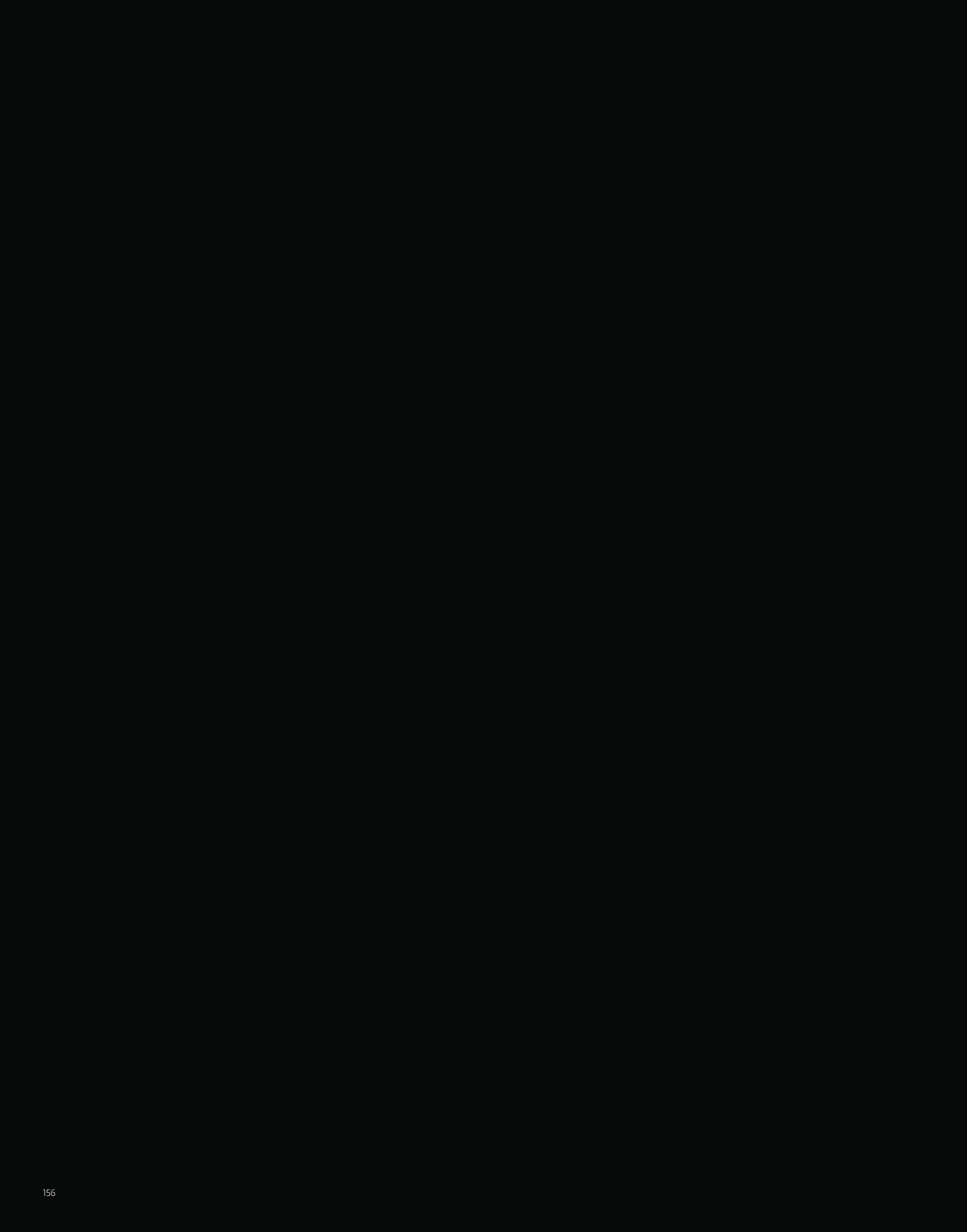

Lampada da parete composta da 4 elementi in metallo verniciato bianco.

Wall mounted lamp made up from 4 elements in white painted metal.

Applique composée de 4 éléments en métal laqués en blanc.

Wandleuchte mit 4 Elementen aus weiß lackiertem Metall.

Escape cube / Parete / Wall-mounted / Applique / Wandleuchte

ESCAPE cube / Design Serena Papait

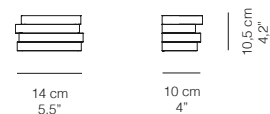

ESCAPE cube	Parete / Wall		SORGENTI LUMINOSE / LIGHT SOURCES		CERTIFICATIONS
	MISURE / DIMENSIONS		HALOG.		
	CM.	INCHES	LED		
12PAWH14	14 x 10 x 10,5H	5,5 x 4 x 4,2H	E-saver 1x28W G9 or 1x42W G9		
12PAWH15	14 x 10 x 10,5H	5,5 x 4 x 4,2H	1x8,7W - Lumen 800 - 2700K		
			LED INCLUSO / LED INCLUDED		
	COLORI / COLOURS				
	Metallo verniciato Bianco / White metal painted				CE IP 20
	OPZIONI / OPTIONS / OPTIONS				
DITV	Dimmer				

LED

12PAWH14

12PAWH15



TUPLA /

Design by the Karboxx Design Centre

Semplicità, funzionalità e razionalità sono i concetti che hanno ispirato la collezione Tupla. Una forma semplice per un utilizzo versatile, quasi universale. Funzionale, perché è una lampada che consente di illuminare abbondantemente e con efficacia lo spazio. Intelligente, perché le sorgenti LED ad elevate prestazioni garantiscono un bassissimo consumo ed una eccezionale durata nel tempo in assenza di manutenzione. Diffusore in metacrilato, struttura in alluminio e sorgente LED sono le caratteristiche tecniche di Tupla.

Schlichtheit, Funktionalität und Vernünftigkeit gaben die Inspiration zur Kollektion Tupla. Eine schlichte Form für die unterschiedlichsten Aufgaben. Funktional, da mit der Leuchte ein Raum gut und effizient beleuchtet werden kann. Intelligente, da mit den hocheffizienten LED ein sehr niedriger Verbrauch und eine hervorragende Lebensdauer ohne Wartung erzielt wird. Ein Diffusor aus Acryl mit Alugestell sind zusammen mit der LED die grundsätzlichen Bestandteile von Tupla.

Simplicity, functionality and rationality are the concepts that inspired the Tupla collection. A simple shape for versatile and almost universal use. This functional lamp gives profuse and effective lighting in a space and its intelligent use of high performance LED bulbs ensure low consumption. The bulbs are exceptionally long-lasting with no need for maintenance. Tupla has a methacrylate diffuser, an aluminium structure and an LED light source.

Simplicité, fonctionnalité et rationalité: voici les concepts à l'origine de la collection Tupla. Une forme simple pour une utilisation polyvalente, presque universelle. Fonctionnelle, car cette lampe permet d'éclairer abondamment et efficacement l'espace. Intelligente, car les LED aux prestations élevées garantissent une consommation très faible et une durée dans le temps exceptionnelle, sans entretien. Le diffuseur en méthacrylate, la structure en aluminium et la source à LED caractérisent d'un point de vue technique Tupla.





Pratica lampada a parete con struttura in alluminio lucidato e diffusori cilindrici in metacrilato opalino. Sorgente LED 220-240 a luce calda. Dimmerabile a taglio di fase.

Functional wall-mounted lamp with polished aluminium structure and cylindrical diffusers in opaline methacrylate. Warm LED light source 220-240. AC phase-cut dimming.

Funktionale Wandleuchte mit gebürstetem Aluminium-Gehäuse und Diffusoren aus mattem Methacrylat. Warmes LED-Licht (220 – 240). Dimmbar.

Applique fonctionnelle avec structure en alu poli et diffuseurs cylindriques en méthacrylate opale. Source LED à lumière chaude 220-240. Avec variateur d'intensité.

Tupla / Parete / Wall-mounted / Applique / Wandleuchte

TUPLA / Design Kxx

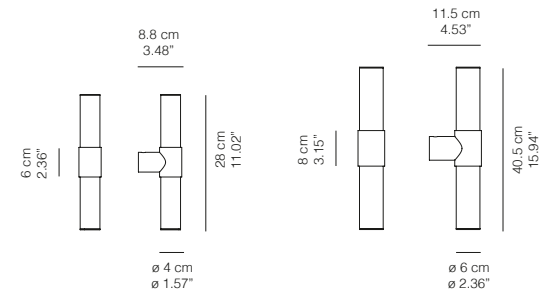

TUPLA		Parete / Wall		SORGENTI LUMINOSE / LIGHT SOURCES		Dimmer a taglio di fase AC phase-cut dimming	
MISURE / DIMENSIONS							
TUPLA 28	CM	INCHES		LED			
27PA01LC	4ø x 8,8 x 28H	1,57ø x 3,46 x 11,02H		2x4,3W - Lumen 800 - 2700K	⊗		
TUPLA 40							
27PA02LC	6ø x 11,5 x 40,5H	2,36ø x 4,53 x 15,94		2x8,7W - Lumen 1600 - 2700K	⊗		
				LED INCLUSO / LED INCLUDED			
				COLORI / COLOURS			
				Struttura in alluminio lucidato / Polished aluminium structure			
				Diffusore metacrilato opalino / Methacrylate opal diffuser			
				CERTIFICATIONS			
				CE IP 44 CLASSE 1			

LED



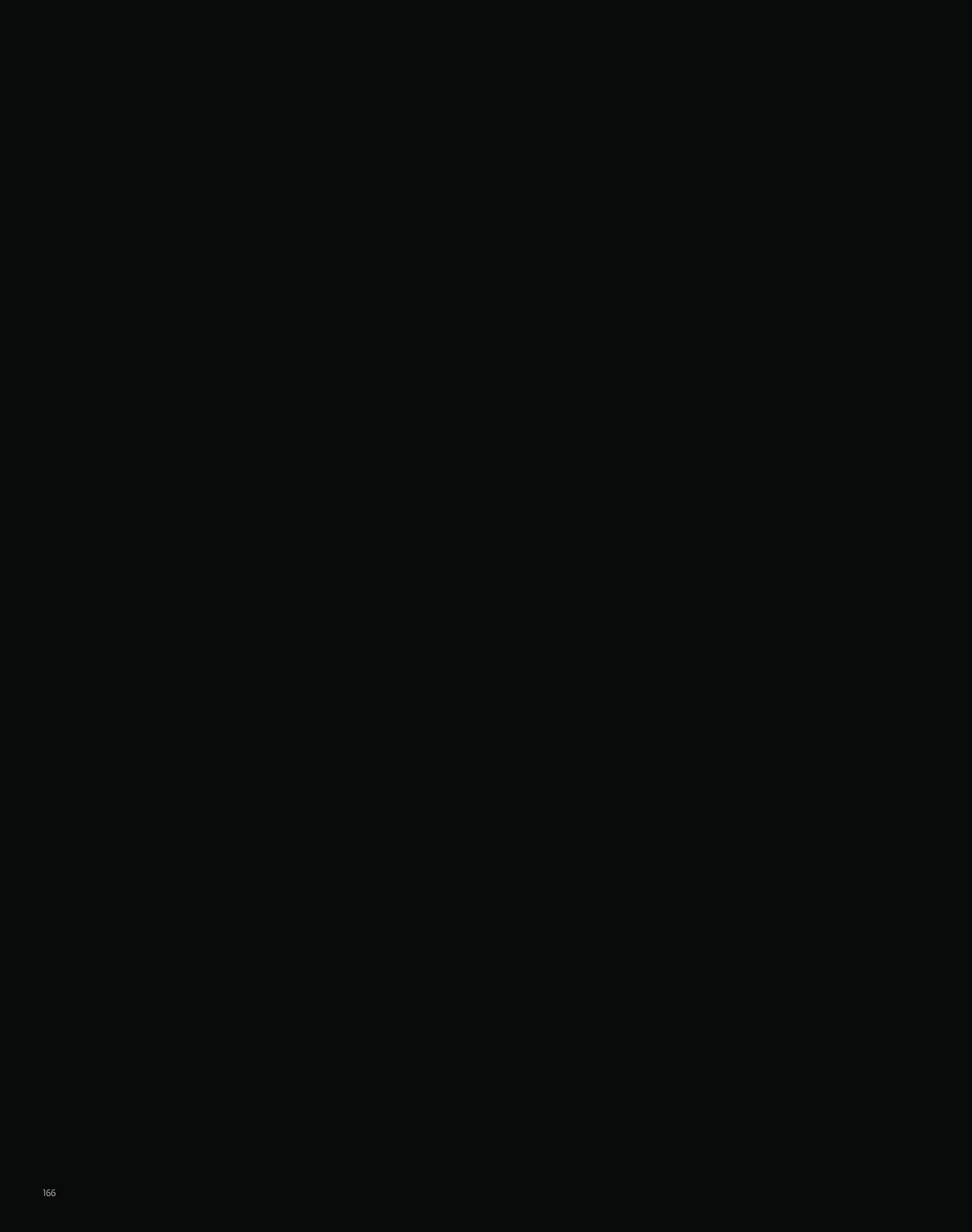

SHINE /

Designed by Moreno De Giorgio

Shine è una forma luminosa semplice, minuta e circolare, impreziosita da tratteggi di luce proiettati sul diffusore frontale. Un'ottica particolare, a misura di LED, emana un'efficace illuminazione radiale sulla parete e, grazie a 35 micro forature nascoste al suo interno, genera una gradevole texture luminosa intorno alla cornice. La magia della luce applicata alle fonti LED trasforma una piccola parte del fascio luminoso in decoro, a dimostrazione delle potenzialità espressive oltre che funzionali delle stesse.

Shine wirkt durch ihre schlichte, kreisförmige Gestalt die durch Lichtstreifen die auf den Diffusor treffen veredelt wird. Eine spezielle Optik für LED strahlt ein effizientes, radiales Licht auf die Wand und dank 35 versteckter Mikrobohrungen auf der Innenseite wird eine angenehme Textur rund um den Rahmen erzeugt. Die Faszination des Lichtes in Verbindung mit LED Technik verwandelt einen kleinen Teil der Lichtstrahlen in Dekoration, wodurch die Persönlichkeit der Leuchte und ihrer Möglichkeiten noch hervorgehoben werden.

Shine is a simple, minute, circular light form, enhanced by traces of light projected on the frontal diffuser. A special perspective, designed for an LED, emits effective radial illumination on the wall and the 35 micro-perforations hidden inside product a pleasant luminous texture around the frame. The magic of light applied to LED bulbs transforms a little part of the beam of light into decoration, demonstrating both its expressive and functional potential.

Shine est une forme lumineuse simple, menue et circulaire, enrichie de pointillés de lumière projetés sur le diffuseur frontal. Une optique spéciale, de la taille d'une LED, émane un éclairage radial efficace sur le mur et, grâce à ses 35 micro trous cachés à l'intérieur, génère une texture lumineuse agréable autour du cadre. La magie de la lumière appliquée aux sources à LED transforme une petite partie du faisceau lumineux en un décor, preuve des ses capacités d'expression et de fonction.



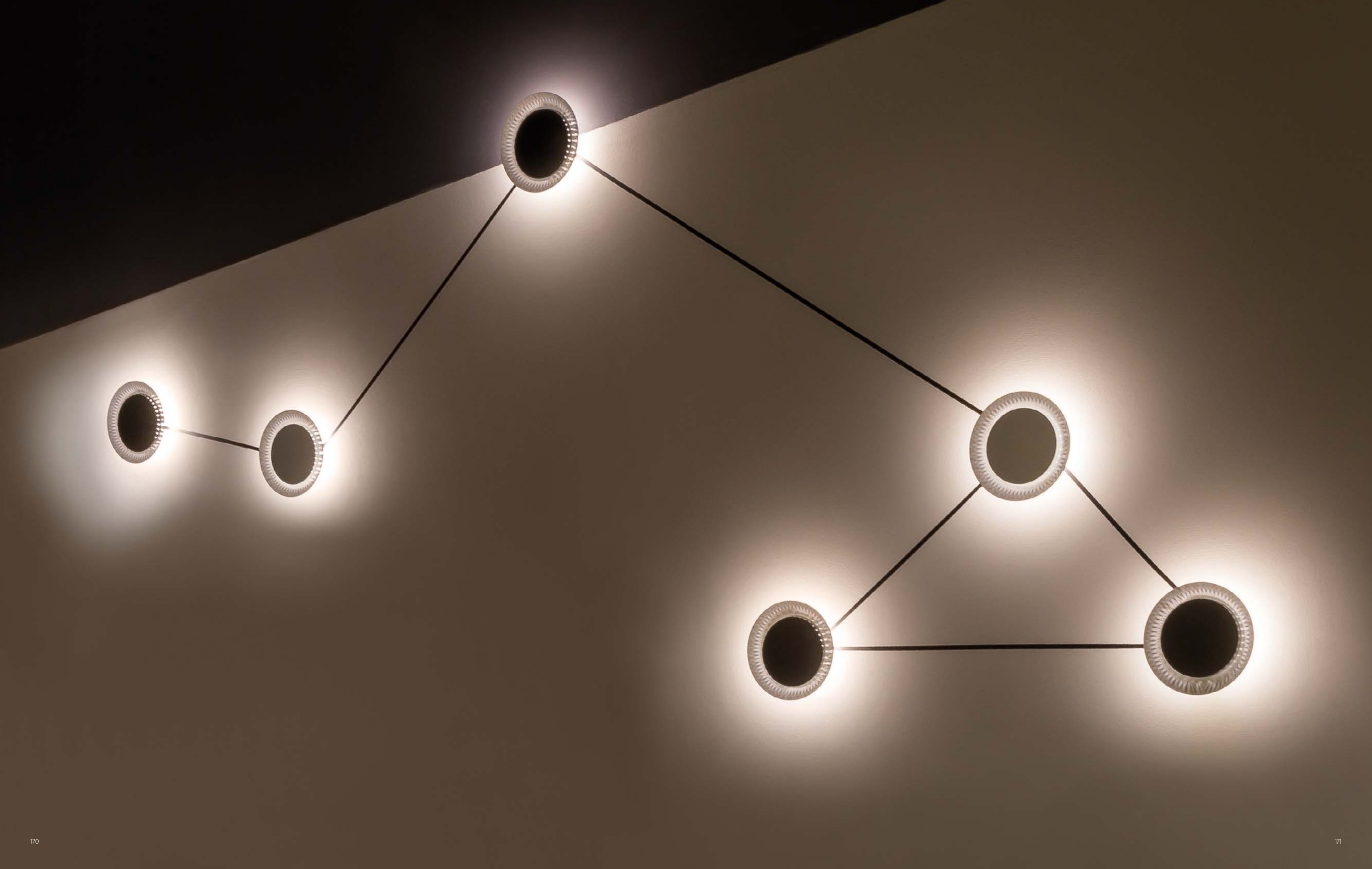

Lampada circolare da parete con struttura in metallo verniciata bianco e parte centrale tonda sempre in metallo verniciato bianco o nero a scelta. I LED diffondono luce calda con un particolare disegno grazie a 35 microforature nascoste.

Circular wall-mounted lamp with white metal structure and a central disk painted in white or black. LED light sources diffuse a warm light with a special design thanks to 35 hidden micro-perforations.

Applique circulaire avec structure en métal laqué blanc et partie centrale ronde laquée blanc ou noir, au choix. Les sources LED diffusent une lumière chaude avec un design spécial grâce aux 35 micro-trous cachés.

Runde Wandleuchte Shine mit schlichter, kreisförmiger Gestalt weiss lackiert, mittige runde Abdeckung in weiß bzw. schwarz lackiert. Effizientes und warmes LED-Licht, das dank 35 versteckter Mikrobohrungen auf der Innenseite eine angenehme Textur rund um den Rahmen erzeugt.

Shine / Parete / Wall-mounted / Applique / Wandleuchte

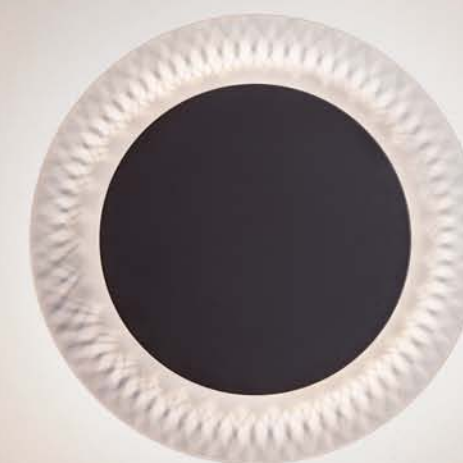
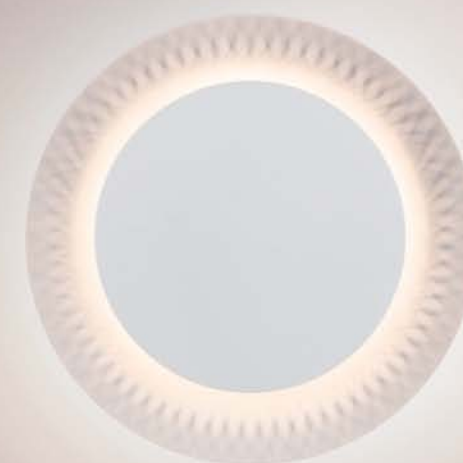

SHINE / Designed by Moreno De Giorgio

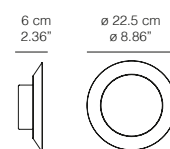

SHINE	Parete / Wall		SORGENTI LUMINOSE / LIGHT SOURCES		CERTIFICATIONS
	MISURE / DIMENSIONS		LED		
	CM.	INCHES	12W - Lumen 1200 - 2700K		
20SP11FL	22,5ø x 6	8,86ø x 2,36	LED INCLUSO / LED INCLUDED		
	COLORI / COLOURS				
21PA01LW	Struttura Bianca, disco centrale Bianco / White structure, White disc				
21PA01LN	Struttura Bianca, disco centrale Nero / White structure, Black disc				

LED

21PA01LW

21PA01LN



TURN ME! /

Design Marta Laudani e Marco Romanelli

È ai LED che in fondo dobbiamo "Turn me!": un foglio di metallo semplicemente si piega su se stesso per ospitare la luce. Il suo aspetto minimale gli consentirà di adattarsi alle più diverse situazioni abitative e l'invenzione da cui nasce il suo nome, ovvero la possibilità di procedere ad una rotazione, consentirà a "Turn me!", con la semplicità di un gesto, di assumere molteplici e sempre mutevoli posizioni sulla parete. Luce verso l'alto, luce verso il basso, verso destra o verso sinistra: quando è isolata "Turn me" si propone come un oggetto poeticamente funzionale, mentre, qualora fosse ripetuta in serie, assumerebbe il valore di un'installazione artistica.

In the end it's the LEDs that give us "Turn me!": a sheet of metal simply folds itself to host light. Its minimal style means it can adapt to many different situations and the invention which gave it its name, that is to say the possibility to rotate, will let "Turn me!" take on multiple mutating positions on the wall, with just a simple touch. Light pointing up, light pointing down, to the left or right: when it stands alone "Turn me" is like a poetically functional object; when a series is repeated it takes on the value of an art installation.

C'est au fond aux LEDs que nous devons "Turn me!": une feuille en métal se plie simplement sur elle-même pour abriter la lumière. Son aspect minimaliste lui permettra de s'adapter aux situations d'habitation les plus diverses et l'invention dont naît son nom, c'est à dire la possibilité d'effectuer une rotation, permettra à "Turn me!", par la simplicité d'un geste, de prendre, sur le mur, des positions nombreuses et toujours changeantes. Lumière vers le haut, lumière vers le bas, vers la droite ou vers la gauche: quand elle est isolée, "Turn me" se propose comme un objet poétiquement fonctionnel, alors que si elle était répétée en série, elle prendrait la valeur d'une installation artistique.

Eigentlich verdanken wir "Turn me!" den LEDs: eine schlichte um sich selbst gebogene Metallfolie, in der das Licht aufgenommen wird. Durch ihr minimalistisches Aussehen passt sie sich jeder Wohnsituation an und durch die Erfindung, der sie ihren Namen verdankt, bzw. die Möglichkeit, gedreht zu werden, gelingt es "Turn me!" mit einer einfachen Geste zahlreiche und immer neue Positionen an der Wand einzunehmen. Nach oben, nach unten, nach rechts oder nach links gerichtetes Licht: alleine ist "Turn me" ein poetischer und funktionaler Gegenstand, während sie in Reihe zu einer kunstvoll gestalteten Installation aufgewertet würde.



Lampada da parete in metallo verniciato bianco opaco con sorgente LED. Può essere facilmente ruotata con la mano direzionando la luce a piacimento.

Wall light fixture in matt white painted metal with LED light source. It can be easily rotated by hand to point the light in the desired direction.

Lampe murale en métal laqué blanc mat avec source LED. Elle peut être facilement tournée avec la main en dirigeant la lumière à son gré.

Wandleuchte aus matt weiß lackiertem Metall mit LED-Lichtquelle. Sie kann leicht von Hand gedreht werden, um das Licht nach Belieben auszurichten.

Turn Me! / Parete / Wall-mounted / Applique / Wandleuchte

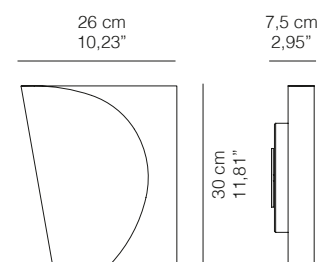

TURN ME! / Design Marta Laudani e Marco Romanelli

Parete/ Wall		SORGENTI LUMINOSE / LIGHT SOURCES		CERTIFICATIONS	
MISURE / DIMENSIONS		LED			
CM.	INCHES	12W Lumen 1300 - 3000K			
19PA26LW	26 x 7,5 x 30H	10,23 x 2,95 x 11,81H	LED INCLUSO / LED INCLUDED		
COLORI / COLOURS				CERTIFICATIONS	
Metallo verniciato Bianco / White painted metal				CE IP 20	

LED

19PA26LW



ALALUNGA /

Design Enrico Franzolini

L'incontro tra fogli metallici piegati su sé stessi per formare due ali che si contrappongono, riflessioni e giochi di luce nuove, ombre geometriche: questa è Alalunga, una nuova ed inedita interpretazione luminosa.

Metal sheets folded upon themselves to form two wings that contrast each other, reflection, new plays of light, geometric shadows: this is Alalunga, a new and unique interpretation of light.

La rencontre entre tôles pliées sur elles-mêmes pour former deux ailes qui se contrastent, réflexions et jeux de lumière, ombres géométriques: c'est le Alalunga, une nouvelle et unique interprétation de la lumière.

Das Treffen zwischen Blechen gefaltet auf sich, um zwei Flügel bilden, Kontrast, Reflexionen und neue Stücke von Licht, geometrische Schatten: Alalunga, eine neue und einzigartige Interpretation hell ist.



Lampada da parete in metallo verniciato bianco opaco o nell'esclusiva finitura "bronzo spazzolato". Sorgente luminosa LED oppure con lampadine fluorescenti compatte.

Wall light fitting in matt white painted metal or the exclusive "brushed bronze" finish. LED light source or compact fluorescent light bulbs.

lackiertem Metall oder in der exklusiven Ausführung "gebürstete Bronze". LED-Lichtquelle oder mit Kompakt-Leuchtstofflampen.

Lampe murale en métal laqué blanc mat ou dans la finition exclusive "bronze brossé". Source lumineuse LED ou bien avec ampoules fluorescentes compactes. Wandleuchte aus matt weiß

Alalunga / Parete / Wall-mounted / Applique / Wandleuchte

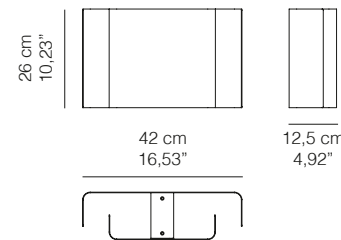

ALALUNGA / Design Enrico Franzolini

ALALUNGA	Parete / Wall		SORGENTI LUMINOSE / LIGHT SOURCES		CERTIFICATIONS
	MISURE / DIMENSIONS				
	CM.	INCHES	FLUO	LED	
18PA42FW	42 x 12,5 x 26H	16,53 x 4,92 x 10,23H	2 x 20W E27	2 x 10W E27	
18PA42FB	42 x 12,5 x 26H	16,53 x 4,92 x 10,23H	2 x 20W E27	2 x 10W E27	
			LED NON INCLUSO / LED NOT INCLUDED		
18PA42LW	42 x 12,5 x 26H	16,53 x 4,92 x 10,23H		12W Lumen 1300 - 3000K	
18PA42LB	42 x 12,5 x 26H	16,53 x 4,92 x 10,23H		12W Lumen 1300 - 3000K	
			LED INCLUSO / LED INCLUDED		
	COLORI / COLOURS				
	Metallo verniciato Bianco / White painted metal (18PA42LW - 18PA42FW)				
	Metallo - Bronzo spazzolato / Metal - brushed bronze finish (18PA42LB - 18PA42FB)				

LED

18PA42LW - 18PA42FW

18PA42LB - 18PA42FB



SHADOW /

Design Enrico Franzolini

Uno schermo in metallo che diffonde la luce in parete senza abbagliare. Luce ed ombra variamente modulabili con un semplice gesto.

A screen in metal that diffuses the light on the wall without dazzling. Light and shadow easily adjustable with a simple action.

Un écran métallique qui diffuse la lumière sur le mur sans éblouir. Ombre et lumière facilement réglables d'un simple geste.

Ein Metallreflektor, der das Licht blendfrei an die Wand strahlt. Licht und Schatten sind durch eine einfache Handbewegung unterschiedlich modulierbar.

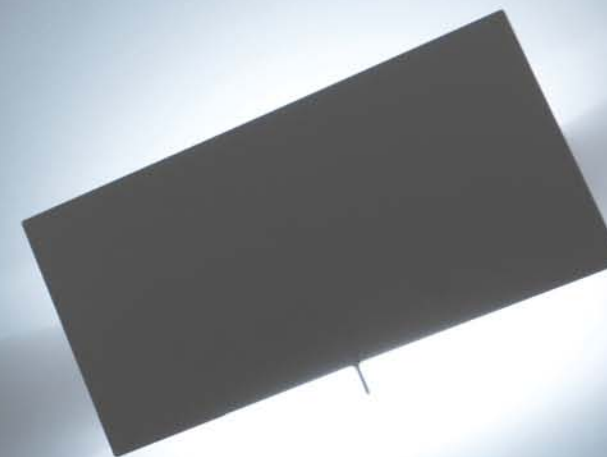
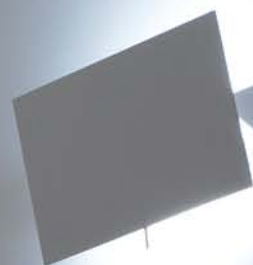

Lampada da parete in metallo,
verniciato bianco o nickel spazzolato.
Diffusore orientabile.

Wall-mounted lamp with adjustable
screen in white painted
metal or brushed nickel.







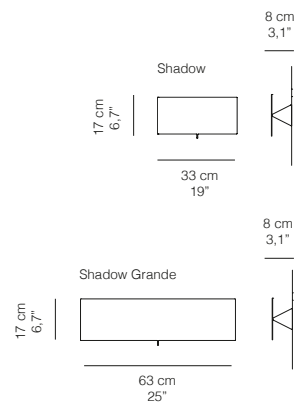



Applique en métal laqué
en blanc ou en nickel brossé.
Diffuseur orientable.

Wandleuchte aus weiß
lackiertem Metall oder Nickel
gebürstet. Der Blendschutz ist
neigbar.

Shadow / Parete / Wall / Applique / Wandleuchte



SHADOW / Design Enrico Franzolini

SHADOW	Parete / Wall		SORGENTI LUMINOSE / LIGHT SOURCES		
	MISURE / DIMENSIONS				
	CM.	INCHES	HALOG.	LED	
SHADOW Piccola					
11PAWH01	33 x 8 x 17H	13 x 3,1 x 6,7H	max 1x100W - R7S 		
11PAWH02	33 x 8 x 17H	13 x 3,1 x 6,7H	max 1x100W - R7S 		
1PA03LN	33 x 8 x 17H	13 x 3,1 x 6,7H		12W Lumen 1300 - 2700K 	
11PA03LW	33 x 8 x 17H	13 x 3,1 x 6,7H		12W Lumen 1300 - 2700K 	
LED INCLUSO / LED INCLUDED					
SHADOW Grande					
11PA06FN (GN)	63 x 8 x 17H	25 x 3,1 x 6,7H	1x24W-T5 G5 		(GN) Dimmer DALI
11PA06FW (GW)	63 x 8 x 17H	25 x 3,1 x 6,7H	1x24W-T5 G5 		(GW) Dimmer DALI
11PA06LN (MN)	63 x 8 x 17H	25 x 3,1 x 6,7H		24W Lumen 2600 - 2700K 	(MN) Dimmer DALI
11PA06LW (MW)	63 x 8 x 17H	25 x 3,1 x 6,7H		24W Lumen 2600 - 2700K 	(MW) Dimmer DALI
LED INCLUSO / LED INCLUDED					
COLORI / COLOURS					
Metallo Bianco / White metal (11PAWH01 / 11PA03LW / 11PA06FW / 11PA06GW / 11PA06LW / 11PA06MW)					
Nikel spazzolato / Brushed nickel (11PAWH02 / 11PA03LN / 11PA06FN / 11PA06GN / 11PA06LN / 11PA06MN)					
OPZIONI/OPTIONS					
LED 3000K su richiesta /LED 3000K on demand					
CERTIFICATIONS					
 					

LED



ADD /

Design Thomas Feichtner

La ceramica modellata a mano, un foro dove far passare la lampadina, il colore. Questa è Add, la tradizione di forme e materiali che si uniscono ad una lampadina. Un insieme di colori per arredare ed illuminare gli spazi della vita quotidiana, un grappolo colorato, classico e moderno allo stesso tempo.

Hand crafted pottery, a slot for the light bulb, colour. This is Add, the tradition of shapes and materials that join up with a light bulb. A mix of colours to furnish and illuminate our living space, a coloured bunch, classical and modern at the same time.

La céramique modelée à la main, un trou où faire passer l'ampoule, la couleur. Ceci est Add, la tradition de formes et matériaux qui s'unissent à une ampoule. Un ensemble de couleurs pour aménager et illuminer les espaces de la vie quotidienne, une grappe colorée, classique et moderne en même temps.

Von Hand geformte Keramik, eine Öffnung für das Leuchtmittel, die Farbe. Das ist ADD, Tradition der Formen und Materialien die sich mit dem Leuchtmittel vereinigen. Ein Zusammenspiel von Farben um unsere unmittelbaren Lebensräume mit Licht zu dekorieren. Eine gelungene Kombination klassischer Ästhetik und moderner Ansprüche.







Paralume in ceramica con l'interno sempre di colore bianco; all'esterno smalto colorato lucido in diversi colori. Solo la finitura "argilla" è opaca. Altri colori su richiesta.

Pottery lightshade coloured white on the inside; outside in glossy enamel in several colours. Only the clay finish is matt. Other colours on request.

Abat-jour en céramique avec l'intérieur toujours de couleur blanche; à l'extérieur vernis coloré brillant en différentes couleurs. Seule la finition "argille" est mate. D'autres couleurs sur demande.
Trépied en métal blanc.

Lampenschirm aus Keramik, bei dem die Innenseite immer weiß ist; außen glänzendes farbiges Email in verschiedenen Farben. Nur die Ausführung "Ton" ist matt. Auf Anfrage sind weitere Farben erhältlich.

Add / Sospensione / Suspended / Suspension / Pendelleuchte

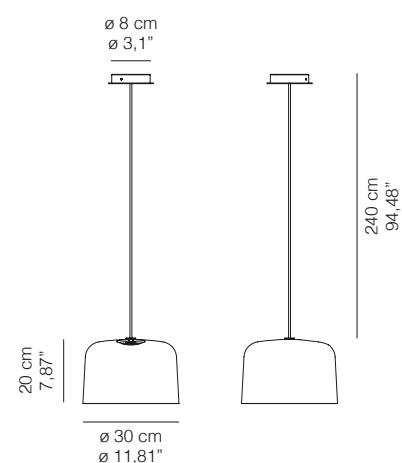

ADD / Designer Thomas Feichtner

ADD	Sospensione / Suspended				
MISURE / DIMENSIONS		SORGENTI LUMINOSE / LIGHT SOURCES			
CM.	INCHES	FLUO		LED	
30ø x 20H	11,81ø x 7,87H	1x23W E27	Globo	1x10W E27	
COLORI / COLOURS		CERTIFICATIONS			
15SP30F2	Ceramica smalto lucido Bianco - Pottery glossy White	CE IP 20			
15SP30F5	Ceramica smalto lucido Arancio - Pottery glossy Orange				
15SP30F7	Ceramica smalto lucido Verde - Pottery glossy Green				
15SP30F8	Ceramica smalto lucido Blu - Pottery glossy Blue				
15SP30F9	Ceramica finitura Argilla opaca - Pottery in matt clay finish				
15SP30F4	Ceramica smalto lucido Bronzo / Pottery glossy Bronze				
OPZIONI / OPTIONS					
5MT	Sospensione cablaggio lunghezza cavi mt. 5,00 / Suspended with longer cables mt. 5,00				



SVEVA /

Design Massimiliano Mornati

Sveva, un'interpretazione contemporanea della lampada a sospensione, un'installazione luminosa dal segno deciso che dà forma all'immaterialità della luce.

Due lame lievemente piegate e contrapposte accolgono la sorgente luminosa e rivelano paesaggi inediti di luci e ombre.

Traslucida con luce diffusa, nella versione in metacrilato satinato, fortemente grafica quella in metallo verniciato.

Sveva, a contemporary interpretation of a suspended lamp, a luminous installation with a strong impact gives shape to immaterial light.

Two slightly bent opposing blades cradle the light source and reveal unusual landscapes of light and shade.

Translucent with diffuse reflection in the brushed methacrylate version, decidedly graphic in the painted metal version.

Sveva, une interprétation contemporaine de la lampe à suspension, une installation lumineuse de style franc qui donne forme à l'immatérialité de la lumière.

Deux lames légèrement pliées et opposées accueillent la source lumineuse et révèlent des paysages inédits de lumières et d'ombres.

Translucide avec une lumière diffuse, dans la version en méthacrylate satiné, la lampe en métal laqué est fortement graphique.

Sveva ist eine zeitgemäße Interpretation der Hängeleuchte, eine helle Installation, die Entschlossenheit erkennen lässt und der Immaterialität des Lichtes Form verleiht.

Zwei leicht gebogene und entgegengesetzt angeordnete Folien umhüllen das Leuchtmittel und bieten völlig neue Licht- und Schattenspiele.

Transluzent mit gedämpftem Licht in der Version aus satiniertem Methacrylat, ein deutlich grafischer Akzent in der Version aus lackiertem Metall.





Lampada da sospensione con sorgente LED diretta ed indiretta. I diffusori sono in metacrilato opalino per una luce diffusa oppure in metallo verniciato bianco opaco per luce diretta ed indiretta.

Suspended lamp with direct and indirect LED light source. The shades are in opaline methacrylate for diffuse reflection or matt white painted metal for direct and indirect light.

Hängeleuchte mit direkter und indirekter LED-Lichtquelle. Diffusoren aus Opal-Methacrylat für gedämpftes Licht oder aus matt weiß lackiertem Metall für direktes und indirektes Licht.

Lampe à suspension avec source LED directe et indirecte. Les diffuseurs sont soit en méthacrylate opalin pour une lumière diffuse, soit en métal laqué blanc mat pour une lumière directe et indirecte.

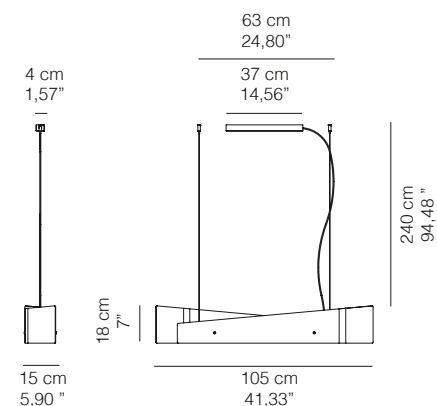

SVEVA / Design Massimiliano Mornati

SVEVA	Sospensione / Suspended		SORGENTI LUMINOSE / LIGHT SOURCES	
	MISURE / DIMENSIONS		LED.	
	CM.	INCHES		
	105 x 15-18H	41,33 x 5,90-7,08H	36W LUMEN 4000 3000K [0000]	
			LED INCLUSO / LED INCLUDED	
	COLORI / COLOURS			
16SP11LM (MW)	Metacrilato bianco opalino / White opaline methacrylate		(MW) Dimmer DALI	
16SP11LW (MW)	Metallo verniciato bianco / White painted metal		(MW) Dimmer DALI	
	OPZIONI / OPTIONS		CERTIFICATIONS	
5MT	Sospensione cablaggio lunghezza cavi mt. 5,00 / Suspended with longer cables mt. 5,00		[CE] [IP 20]	

Sveva / Opaline methacrylate and white metal



LED

16SP11LM

16SP11LW



GOUT /

Design Enrico Franzolini

Un calice in vetro soffiato.
Un fiore che sboccia con il suo gambo.
Un pensiero delicato, fluido, elegante.
Lampada da sospensione che produce
un'emissione di luce diretta e diffusa.
Il diffusore, prodotto in vetro soffiato
a bocca, è disponibile nei colori bianco
oppure nero.

A chalice in hand blown glass.
A flower with its stem, that
blooms. A delicate, fluid and
elegant thought. Suspension
lamp providing direct
and diffused light emission.
The diffuser in blown glass
is available in white or black
color.

Une bulle en verre soufflé.
Une fleur qui fleurit sur sa tige.
Une pensée fluide et élégante.
La suspension émet une
lumière directe et diffuse à la
fois. Le diffuseur en verre soufflé
est disponible en couleurs
blanc ou noir.

Eine knospende Blume, ein
zarter, flüssiger und eleganter
Gedanke. Eine Pendelleuchte,
die diffuses und direktes Licht
abgibt. Der Diffusor, aus mund-
geblasenem Glas hergestellt, ist
in weiß oder schwarz erhältlich.



Lampada a sospensione con diffusore in vetro soffiato a bocca disponibile in colore bianco o nero. Asta e rosone in metallo verniciato nero.

Suspension lamp providing direct and diffused light emission. The diffuser in blown glass is available in white or black color. The stem, ceiling rose and cable in black color.

Pendelleuchte mit Lampenschirm aus mundgeblasenem Glas in weiß oder schwarz erhältlich. Die Stange und die Deckenrose sind aus weiß oder schwarz lackiertem Metall.

Suspension avec diffuseur en verre soufflé à la bouche disponible en blanc ou noir. Tige et rosace en métal noir.

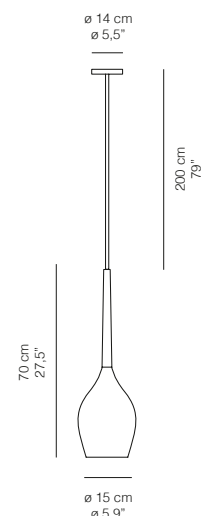

GOUT / Design Enrico Franzolini

GOUT	Sospensione / Suspended		SORGENTI LUMINOSE / LIGHT SOURCES	
	MISURE / DIMENSIONS		FLUO	LED
	CM.	INCHES	1x20W E27	1x10W E27
	15ø x 70-200H	5,9ø x 27,5-79H		
	COLORI / COLOURS		CERTIFICATIONS	
14SPWH01	Vetro Bianco / White Glass		□ ▽ CE IP 20	
14SPBK02	Vetro Nero / Black Glass			
	OPZIONI / OPTIONS			
5MT	Sospensione cablaggio lunghezza cavi mt. 5,00 / Suspended with longer cables mt. 5,00			



14SPWH01

14SPBK02

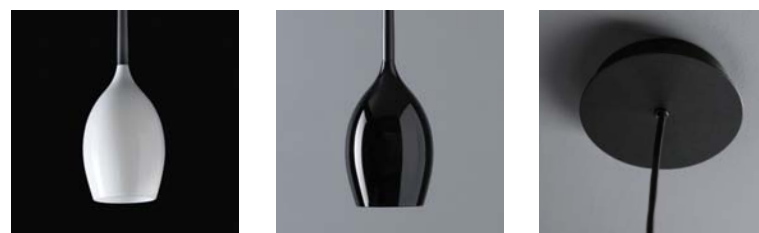

SUN /

Design Brian Rasmussen

Sun tratta il tema della luce sulla superficie della lampada: il tema del chiaro-scuro. Le aperture sul paralume permettono alla luce di giocare, riflettersi, di sottolinearne la forma sferica creando una serie di esplosioni luminose proprio come il sole... Il paralume è disponibile in due materiali: resina sintetica bianca ed un elegante tessuto nei colori bianco, rosso e nero. La collezione comprende le versioni sospensione, tavolo con diametro 50 cm, mentre il diametro più grande – 75 cm – è disponibile nel modello sospensione.

Sun explores the theme of light on the surface of the lamp: the theme of brightness and shadow. The slits on the shade allow the light to dance, glimmer and underscore the spherical shape creating a series of luminous explosions just like the sun itself... The shade is available in two different materials: white synthetic resin and an elegant textile fabric in white, red and black. Sun collection is hanging, table and suspended 50 cm diameter. The hanging version also in 75 cm diameter.

Sun explore le thème de la lumière à la surface de la lampe: le thème de l'ombre et la lumière. Les ouvertures dans l'ombre permettent à la lumière de danser, elles reflètent et soulignent la forme sphérique créant ainsi une série d'explosions lumineuses un peu comme le soleil lui-même! Disponible au choix en 2 matériaux différents: résine de synthèse de couleurs blanc ou élégant tissu blanc, rouge, ou noir. La collection SUN est constituée d'une version à poser en diamètre 50 cm et d'une version suspendue en diamètre 50 et 75 cm.

Sun erforscht das Thema des Lichts auf der Oberfläche der Leuchte: das Thema hell und dunkel. Die Öffnungen auf dem Lampenschirm lassen das Licht spielen und reflektieren. Die Kugelform unterstreicht die Schaffung einer Reihe von leuchtenden Explosionen wie die Sonne selbst... Der Schirm ist in zwei verschiedenen Materialien erhältlich: weiß Kunstharz und ein elegantes Textilgewebe in weiss, rot und schwarz. Die Kollektion „Sun“ bietet Pendelleuchten und Tischleuchten mit 50 cm Durchmesser, die Pendelleuchte ist auch in 75 cm Durchmesser erhältlich.



Lampada da sospensione costruita incastrando 96 volte sottilissimi fogli di tessuto bianco, rosso, nero o resina bianca. Rosone in metallo verniciato nero.

Suspended lamp made by slotting together 96 times very thin sheets of white textile fabric red, black or white resin. Support in black-painted metal.

Pendelleuchte die aus 96 dünnen aneinandergereihten Elementen aus weißem, roten oder schwarzen Stoff oder aus weißem Kunstharz besteht. Deckenrose schwarz lackiert.

Suspension construite en encastrant 96 fois des feuilles très mince en tissu blanc, rouge, noir ou résine blanche. Support en métal noir.

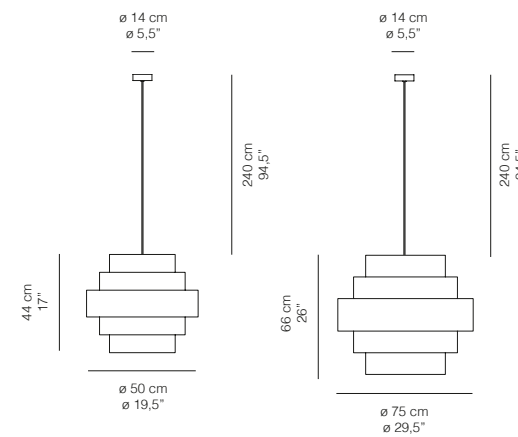

SUN / Design Brian Rasmussen

SOSPENSIONE / SUSPENDED		MISURE / DIMENSIONS		SORGENTI LUMINOSE / LIGHT SOURCES		CERTIFICATIONS	
CM.	INCHES			FLUO	LED		
SUN 50	50ø x 44-240H	19,5ø x 17-94,5H		1x40W E27	1x16W E27		
SUN 75	75ø x 66-240H	29,5ø x 26-94,5H		3x20W E27	3x10W E27		
SUN 50	COLORI / COLOURS				CERTIFICATIONS		
05SPWH50S	Tessuto Bianco / White Textile fabric				☐ ▽ CE IP 20		
05SPRD50S	Tessuto Rosso / Red Textile fabric						
05SPBK50S	Tessuto Nero / Black Textile fabric						
05SPWH01	Resina Bianca / White resin						
SUN 75	COLORI / COLOURS				CERTIFICATIONS		
05SPWH75S	Tessuto Bianco / White Textile fabric				☐ ▽ CE IP 20		
05SPRD75S	Tessuto Rosso / Red Textile fabric						
05SPBK75S	Tessuto Nero / Black Textile fabric						
05SPWH75	Resina Bianca / White resin						
	OPZIONI / OPTIONS						
5MT	Sospensione cablaggio lunghezza cavi mt. 5,00 / Suspended with longer cables mt. 5,00						

05SPWH50S
05SPWH75S

05SPBK50S
05SPBK75S

05SPRD50S
05SPRD75S

05SPWH01
05SPWH75

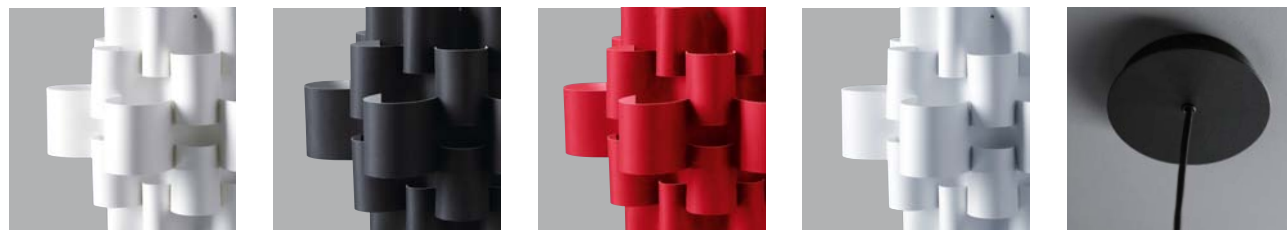



Lampada da tavolo costruita incastrando 96 volte sottilissimi fogli di tessuto bianco, rosso, nero o resina bianca. Base in metallo verniciata grigio chiaro.

Table lamp made by slotting together 96 times very thin sheets of white textile fabric, red, black or white resin. Base in metal painted light grey.

Tischleuchte die aus 96 dünnen aneinandergereihten Elementen aus weißem, roten oder schwarzen Stoff oder aus weißem Kunstharz besteht. Stütze hellgrau lackiert.

Lampe de table construite en encastrant 96 fois des feuilles très mince en tissu blanc, rouge, noir ou résine blanche. Base en métal laqué gris clair.

Sun / Tavolo / Table / Table / Tischleuchte

SUN / Design Brian Rasmussen

SUN		Tavolo / Table		SORGENTI LUMINOSE / LIGHT SOURCES		CERTIFICATIONS	
MISURE / DIMENSIONS		MISURE / DIMENSIONS		FLUO		LED	
CM.	INCHES	CM.	INCHES	1x40W E27	1x16W E27	CE	IP 20
50ø x 44-71H	19,5ø x 17-28H						
COLORI / COLOURS		COLORI / COLOURS					
05TVWH50S	Tessuto Bianco / White Textile fabric	05TVBK50S	Tessuto Nero / Black Textile fabric				
05TVRD50S	Tessuto Rosso / Red Textile fabric	05TVWH01	Resina Bianca / White resine				
05TVBK50S	Tessuto Nero / Black Textile fabric						
05TVWH01	Resina Bianca / White resine						

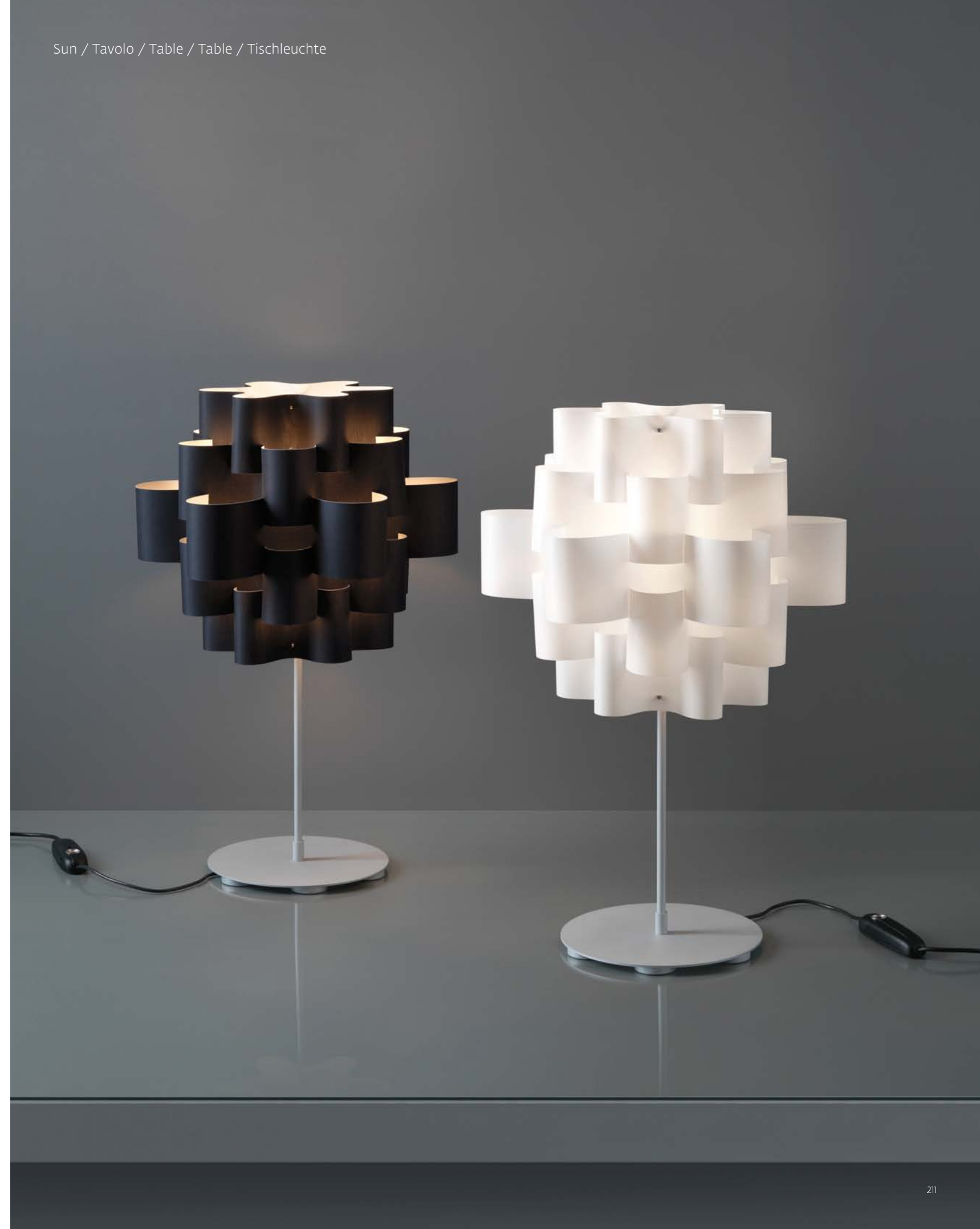
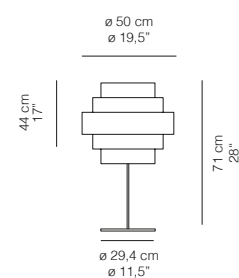

DRINK /

Design Enrico Franzolini with Vicente Garcia Jimenez

Collezione composta da lampade da terra e soffitto, in fibra di carbonio o in composito di fibra di vetro verniciata. nera orientabile a 360° e inclinabile di 25°. La versione soffitto è disponibile nella versione monocono o bicono, in due misure d'altezza, 127 cm o 175 cm.

A collection composed of floor, ceiling and suspended lamps in black carbon fibres with metal base painted black or in painted composite fibreglass, pivots 360° and angle of tilt 25°. The suspended version is available with a single or twin cones in two different lengths of 127 cm and 175 cm.

Lampadaire et plafonnier orientable à 360 degrés et inclinable à 25 degrés. Cône en fibre de carbone ou en composite de fibre de verre laquée. Disponible en longueur 127 cm ou 175 cm. Base en métal.

Kollektion DRINK bestehend aus Boden und Deckenleuchten 360°drehbar und 25° neigbar. Kegel aus Karbon oder aus lackierter Glasfaser lieferbar. Länge 127 cm oder 175 cm.



Lampada da soffitto orientabile a 360° e inclinabile di 25°. Cono in fibra di carbonio o in composito di fibra di vetro verniciata. disponibile nella lunghezza di cm 127 oppure cm 175. Base in metallo.

Ceiling lamp that can pivot 360° and tilt angle 25°. Cone in carbon fibre or in painted composite fibreglass. length available cm 127 or cm 175. Base in metal.

Deckenleuchten 360°drehbar und 25° neigbar. Kegel aus Karbon oder aus lackierter Glasfaser lieferbar. Länge 127 cm oder 175 cm.

Plafonnier orientable à 360 degrés et inclinable à 25 degrés. Cône en fibre de carbone ou en composite de fibre de verre laquée. Disponible en longueur 127 cm ou 175 cm. Base en métal.

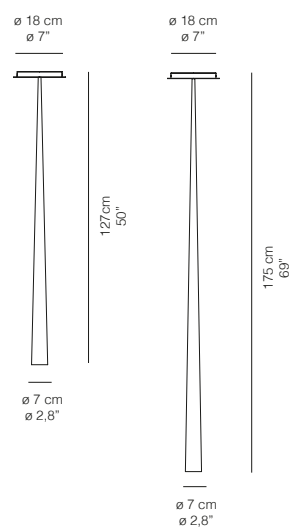

DRINK / Design Enrico Franzolini with Vicente Garcia Jimenez

Soffitto / Ceiling		SORGENTI LUMINOSE / LIGHT SOURCES		CERTIFICATIONS	
MISURE / DIMENSIONS		HALOG.		LED	
CM.	INCHES				
DRINK 127	7-18ø x 127H	2,8-7ø x 50H	max 1x50W 12V GUS.3 - MR16	1x10W 12V GUS.3 - MR16	
DRINK 175	7-18ø x 175H	2,8-7ø x 69H	max 1x50W 12V GUS.3 - MR16	1x10W 12V GUS.3 - MR16	
COLORI / COLOURS				CERTIFICATIONS	
DRINK 127				V CE IP 20	
04SP12701		Fibra di carbonio / Carbon fibre			
04SP1270+2/3/5/6		Fibra di vetro / Fibreglass: Bianco / White (2) - Rosso / Red (3) - Arancio / Orange (5) - Argento / Silver (6)			
COLORI / COLOURS				CERTIFICATIONS	
DRINK 175				V CE IP 20	
04SP17501		Fibra di carbonio / Carbon fibre			
04SP1750+2/3/5/6		Fibra di vetro / Fibreglass: Bianco / White (2) - Rosso / Red (3) - Arancio / Orange (5) - Argento / Silver (6)			



Drink 127-175 / Soffitto / Ceiling / Plafonnier / Deckenleuchte

DRINK /

Design Enrico Franzolini
with Vicente Garcia Jimenez



Lampada da soffitto orientabile a 360° e inclinabile di 25°. Cono in fibra di carbonio o in composito di fibra di vetro verniciata, disponibile nella lunghezza di cm 127 oppure cm 175.

Ceiling lamp that can pivot 360° and tilt angle 25°. Cone in carbon fibre or in painted composite fibreglass length available cm 127 or cm 175. Base in painted metal.

Deckenleuchten 360°drehbar und 25° neigbar. Kegel aus Kohlenstoff lieferbar oder aus Glasfaserstoff lackiert in der Länge 127 cm oder 175 cm.

Plafonnier orientable à 360 degrés et inclinable à 25 degrés. Cône en fibre de carbone ou en composite de fibre de verre laquée disponible en longueur 127 cm ou 175 cm.

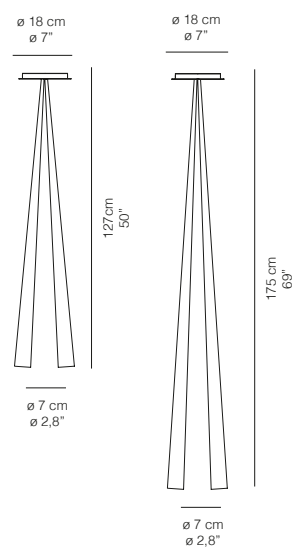

DRINK bicono / Design Enrico Franzolini with Vicente Garcia Jimenez

Soffitto / Ceiling		SORGENTI LUMINOSE / LIGHT SOURCES		CERTIFICATIONS	
MISURE / DIMENSIONS		HALOG.		LED	
CM.	INCHES				
DRINK 127 BICONO	7-18ø x 127H	2,8-7ø x 50H	max 2x50W 12V GU5.3 - MR16	1x10W 12V GU5.3 - MR16	
DRINK 175 BICONO	7-18ø x 175H	2,8-7ø x 69H	max 2x50W 12V GU5.3 - MR16	1x10W 12V GU5.3 - MR16	
DRINK 127 BICONO		COLORI / COLOURS		CERTIFICATIONS	
04SP12701/B	Fibra di carbonio / Carbon fibre		V		CE IP 20
04SP1270+2/3/5/6/B	Fibra di vetro / Fibreglass: Bianco / White (2) - Rosso / Red (3) - Arancio / Orange (5) - Argento / Silver (6)		V		CE IP 20
DRINK 175 BICONO		COLORI / COLOURS		CERTIFICATIONS	
04SP17501/B	Fibra di carbonio / Carbon fibre		V		CE IP 20
04SP1750+2/3/5/6	Fibra di vetro / Fibreglass: Bianco / White (2) - Rosso / Red (3) - Arancio / Orange (5) - Argento / Silver (6)		V		CE IP 20

04SP12702/B
04SP17502/B



04SP12705/B
04SP17505/B



04SP12705/B
04SP17505/B



04SP12706/B
04SP17506/B



04SP12701/B
04SP17501/B

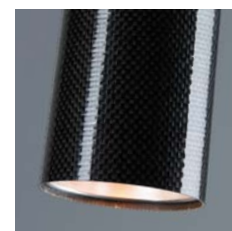

Drink 127-175 Bicono
Soffitto / Ceiling / Plafonnier / Deckenleuchte

Lampada a sospensione realizzata in fibra di carbonio oppure in composito di fibra di vetro verniciato. Su richiesta disponibile in tutti i colori.

Suspended lamp in carbon fibre or in composite Fibreglass painted. On request, any color available.

Pendelleuchte aus Karbon oder aus lackierter Glasfaser lieferbar. Auf Wunsch in allen Farben lieferbar.

Suspension créée en fibre de carbone ou en fibre de verre laquée. Sur demande disponible dans toutes les couleurs.

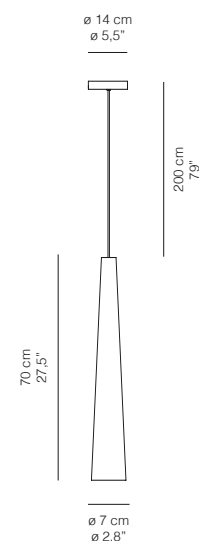

DRINK 70 / Design Enrico Franzolini with Vicente Garcia Jimenez

DRINK 70		Sospensione / Suspended		SORGENTI LUMINOSE / LIGHT SOURCES	
MISURE / DIMENSIONS		MISURE / DIMENSIONS		SORGENTI LUMINOSE / LIGHT SOURCES	
CM.	INCHES	HALOG.	LED		
7-14ø x 70H	2,8-5,5ø x 27,5H	max 1x50W 12V GU5.3 MR16	1x10W 12V GU5.3 MR16		
COLORI / COLOURS		COLORI / COLOURS		CERTIFICATIONS	
04SP07001	Fibra di carbonio / Carbon fibre	04SP0700+2/3/5/6		Fibra di vetro / Fibreglass: Bianco / White (2) - Rosso / Red (3) - Arancio / Orange (5) - Argento / Silver (6)	
OPZIONI / OPTIONS		OPZIONI / OPTIONS		CERTIFICATIONS	
5MT	Sospensione cablaggio lunghezza cavi mt. 5,00 / Suspended with longer cables mt. 5,00			CE IP 20	



Drink 70 / Sospensione / Suspended / Suspension / Pendelleuchte



Lampada da terra orientabile a 360° e inclinabile di 25°. Cono in fibra di carbonio o in composito di fibra di vetro verniciata e base in metallo verniciato nero.

Floor lamp that can pivot 360° and tilt angle 25° cone in carbon fibre or in painted composite fibreglass and base in black-painted metal.

Stehleuchte 360°drehbar und 25° neigbar. Kegel aus Karbon oder aus lackierter Glasfaser lieferbar. Stehfuß aus schwarz lackiertem Metall.

Lampadaire orientable à 360 degrés et inclinable à 25 degrés. Cône en fibre de carbone ou en composite de fibre de verre laquée et base en métal noir.

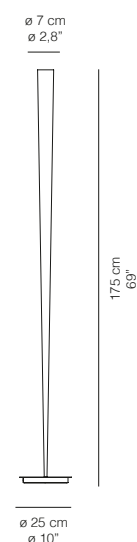

DRINK / Design Enrico Franzolini with Vicente Garcia Jimenez

DRINK	Terra / Floor	SORGENTI LUMINOSE / LIGHT SOURCES		CERTIFICATIONS
	MISURE / DIMENSIONS			
	CM. INCHES	HALOG.	LED	
	7-25Ø x 175H 2,8-10Ø x 69H	max 1x50W 12V GU5.3 - MRI6	1x10W 12V GU5.3 - MRI6	
	COLORI / COLOURS			
04TR17501	Fibra di carbonio / Carbon fibre			
04TR1750+2/3/5/6	Fibra di vetro / Fibreglass: Bianco / White (2) - Rosso / Red (3) - Arancio / Orange (5) - Argento / Silver (6)			
		CE IP 20		

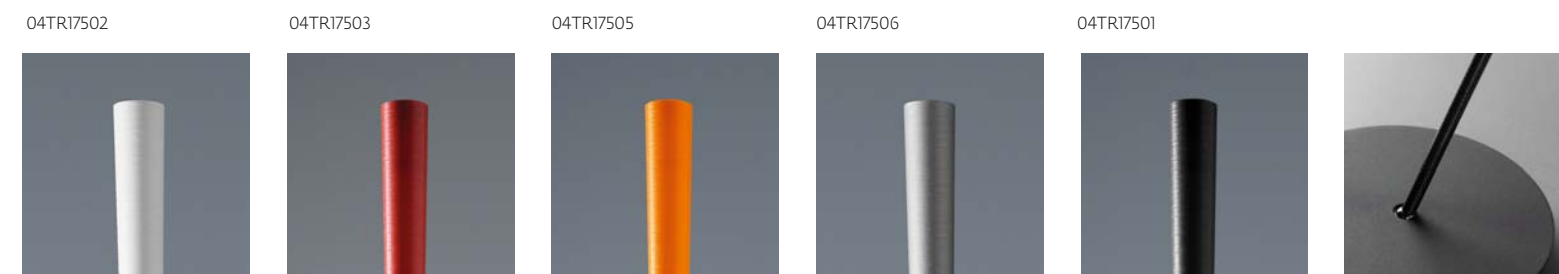

Drink / Terra / Floor / Lampadaire / Stehleuchte



SLICE /

Design Enrico Franzolini with Vicente Garcia Jimenez

Collezione composta da lampade a sospensione, parete e soffitto, disponibili in diversi diametri e lunghezze. I cilindri sono realizzati in fibra di carbonio o in composito di fibra di vetro verniciata con taglio obliquo ed interno colorato.

Collection made up of hanging, wall and ceiling lamps, available in various diameters and lengths. The cylinders are in carbon fibre or in painted composite fibreglass with oblique cut and colorful interior.

Suspension, plafonnier et applique créée en fibre de carbone ou en fibre de verre laquées. Sur demande disponible dans toutes les couleurs coupe oblique, intérieur 3 couleurs possible.

Kollektion Slice mit Pendel-, Wand- und Deckenleuchten, in diversen Durchmessern und Längen erhältlich. Zylinder mit schrägem Schnitt aus Karbon oder lackierter Glasfaser. Auf der Innenseite lackiert. Auf Anfrage in allen Farben lieferbar.



Lampada a sospensione realizzata in fibra di carbonio oppure in composito di fibra di vetro verniciato. Su richiesta disponibile in tutti i colori.

Suspended lamp in carbon fibre or in composite Fibreglass painted. On request, any color available.

Pendelleuchte aus Kohlenstoff oder Glasfaser lackiert. Auf Wunsch in allen Farben lieferbar.

Suspension créée en fibre de carbone ou en fibre de verre laquées. Sur demande disponible dans toutes les couleurs.

02SP0302G
02SP0402G
02SP0702G

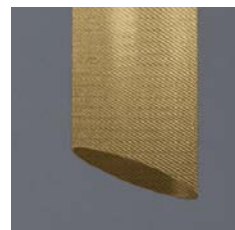

Special Gold Edition (G)

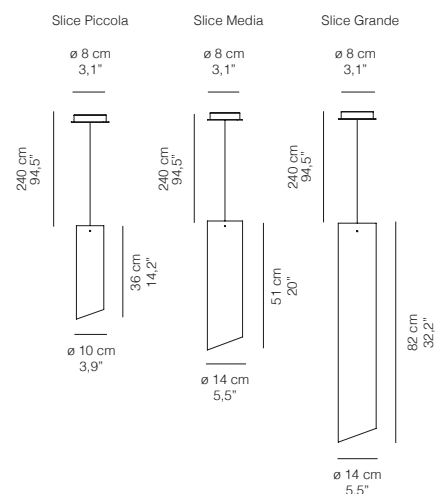

SLICE / Design Enrico Franzolini with Vicente Garcia Jimenez

Sospensione / Suspended

MISURE / DIMENSIONS

	CM.	INCHES
SLICE Piccola	10ø x 36-240H	3,9ø x 14,2-94,5HH
SLICE Media	14ø x 51-240H	5,5ø x 20-94,5HH
SLICE Grande	14ø x 82-240H	5,5ø x 32,2-94,5HH

SORGENTI LUMINOSE / LIGHT SOURCES

HALOG.	LED	FLUO
max 1x75W E27 PAR 30S	1x11W 230V E27 PAR 30S	
max 1x100W E27 PAR 38	1x16W E27 PAR 38	1x23W E27 PAR 38
max 1x100W E27 PAR 38	1x16W E27 PAR 38	1x23W E27 PAR 38

COLORI / COLOURS

SLICE Piccola 02SP0301+/Y/R/O 02SP0302+/Y/R/O 02SP0302G	Fibra di carbonio / Carbon fibre - Interno giallo / yellow inside (Y) - Interno rosso / red inside (R) - Interno arancio / orange inside (O) Fibra di vetro bianco / White Fibreglass - Interno giallo / yellow inside (Y) - Interno rosso / red inside (R) - Interno arancio / orange inside (O) Fibra di vetro oro / Gold Fibreglass - Interno oro / Gold inside
---	--

COLORI / COLOURS

SLICE Media 02SP0401+/Y/R/O 02SP0402+/Y/R/O 02SP0402G	Fibra di carbonio / Carbon fibre - Interno giallo / yellow inside (Y) - Interno rosso / red inside (R) - Interno arancio / orange inside (O) Fibra di vetro bianco / White Fibreglass - Interno giallo / yellow inside (Y) - Interno rosso / red inside (R) - Interno arancio / orange inside (O) Fibra di vetro oro / Gold Fibreglass - Interno oro / Gold inside
---	--

COLORI / COLOURS

SLICE Grande 02SP0701+/Y/R/O 02SP0702+/Y/R/O 02SP0702G	Fibra di carbonio / Carbon fibre - Interno giallo / yellow inside (Y) - Interno rosso / red inside (R) - Interno arancio / orange inside (O) Fibra di vetro bianco / White Fibreglass - Interno giallo / yellow inside (Y) - Interno rosso / red inside (R) - Interno arancio / orange inside (O) Fibra di vetro oro / Gold Fibreglass - Interno oro / Gold inside
--	--

OPZIONI / OPTIONS

SMT	Sospensione cablaggio lunghezza cavi mt. 5,00 / Suspended with longer cables mt. 5,00
-----	---

CERTIFICATIONS

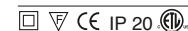

CERTIFICATIONS

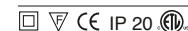

CERTIFICATIONS

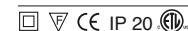

02SP0302/R
02SP0402/R
02SP0702/R



02SP0302/O
02SP0402/O
02SP0702/O



02SP0302/Y
02SP0402/Y
02SP0702/Y



02SP0301/R
02SP0401/R
02SP0701/R



02SP0301/O
02SP0401/O
02SP0701/O



02SP0301/Y
02SP0401/Y
02SP0701/Y

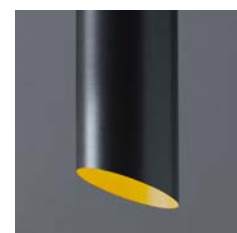

Slice Piccola / Media / Grande / Sospensione / Suspended / Suspension / Pendelleuchte

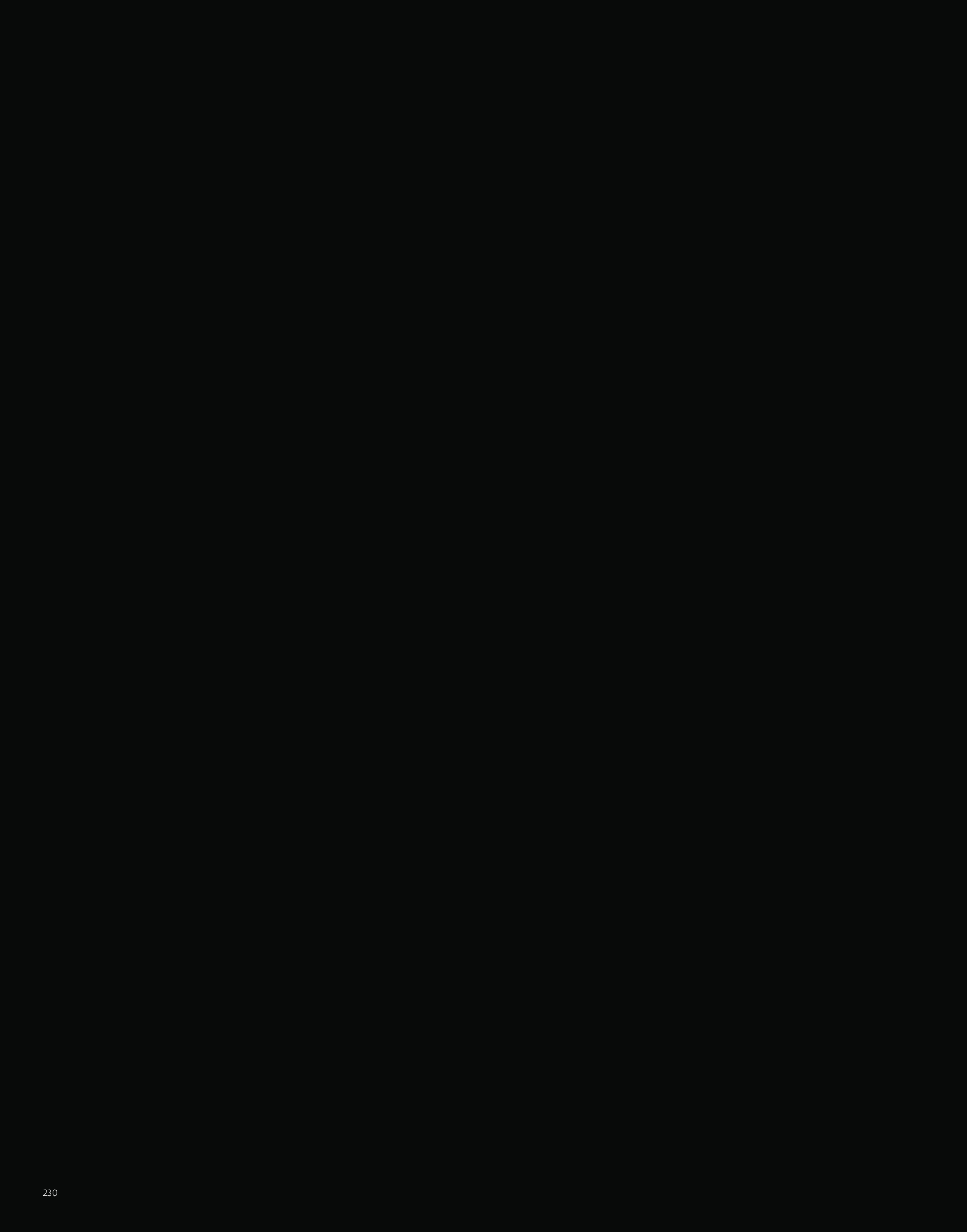

Lampada da soffitto realizzata in fibra di carbonio oppure in composito di fibra di vetro verniciato. Su richiesta disponibile in tutti i colori.

Ceiling lamp in carbon fibre or in composite Fibreglass painted. On request, any color available.

Deckenleuchte aus Kohlenstoff oder Glasfaser lackiert. Auf Wunsch in allen Farben lieferbar.

Plafonnier créée en fibre de carbone ou en fibre de verre laquées. Sur demande disponible dans toutes les couleurs.

02SF0302G
02SF0402G
02SF0702G

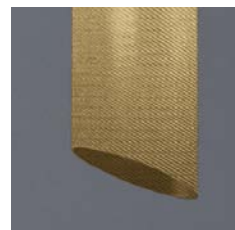

Special Gold Edition (G)

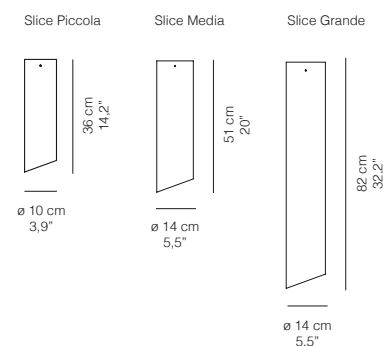

SLICE / Design Enrico Franzolini with Vicente Garcia Jimenez

Soffitto / Ceiling		SORGENTI LUMINOSE / LIGHT SOURCES			
MISURE / DIMENSIONS		HALOG.	LED	FLUO	
CM.	INCHES				
SLICE Piccola	10ø x 36H	3,9ø x 14,2H	max 1x75W E27 PAR 30S	1x11W 230V E27 PAR 30S	
SLICE Media	14ø x 51H	5,5ø x 20H	max 1x100W E27 PAR 38	1x16W E27 PAR 38	1x23W E27 PAR 38
SLICE Grande	14ø x 82H	8,2ø x 32,2H	max 1x100W E27 PAR 38	1x16W E27 PAR 38	1x23W E27 PAR 38
COLORI / COLOURS		CERTIFICATIONS			
SLICE Piccola		☑ ☑ CE IP 20			
02SF0301+Y/R/O		Fibra di carbonio / Carbon fibre - Interno giallo/yellow inside (Y) - Interno rosso / red inside (R) - Interno arancio / orange inside (O)			
02SF0302+Y/R/O		Fibra di vetro bianco / White Fibreglass - Interno giallo / yellow inside (Y) - Interno rosso / red inside (R) - Interno arancio / orange inside (O)			
02SF0302G		Fibra di vetro oro / Gold Fibreglass- Interno oro / Gold inside			
SLICE Media		☑ ☑ CE IP 20			
02SF0401+Y/R/O		Fibra di carbonio / Carbon fibre - Interno giallo / yellow inside (Y) - Interno rosso / red inside (R) - Interno arancio / orange inside (O)			
02SF0402+Y/R/O		Fibra di vetro bianco / White Fibreglass - Interno giallo / yellow inside (Y) - Interno rosso / red inside (R) - Interno arancio / orange inside (O)			
02SF0402G		Fibra di vetro oro / Gold Fibreglass - Interno oro / Gold inside			
SLICE Grande		☑ ☑ CE IP 20			
02SF0701+Y/R/O		Fibra di carbonio / Carbon fibre - Interno giallo / yellow inside (Y) - Interno rosso / red inside (R) - Interno arancio / orange inside (O)			
02SF0702+Y/R/O		Fibra di vetro bianco / White Fibreglass - Interno giallo / yellow inside (Y) - Interno rosso / red inside (R) - Interno arancio / orange inside (O)			
02SF0702G		Fibra di vetro oro / Gold Fibreglass -Interno oro / Gold inside			

Slice Piccola / Media / Grande / Soffitto / Ceiling / Plafonnier / Deckenleuchte

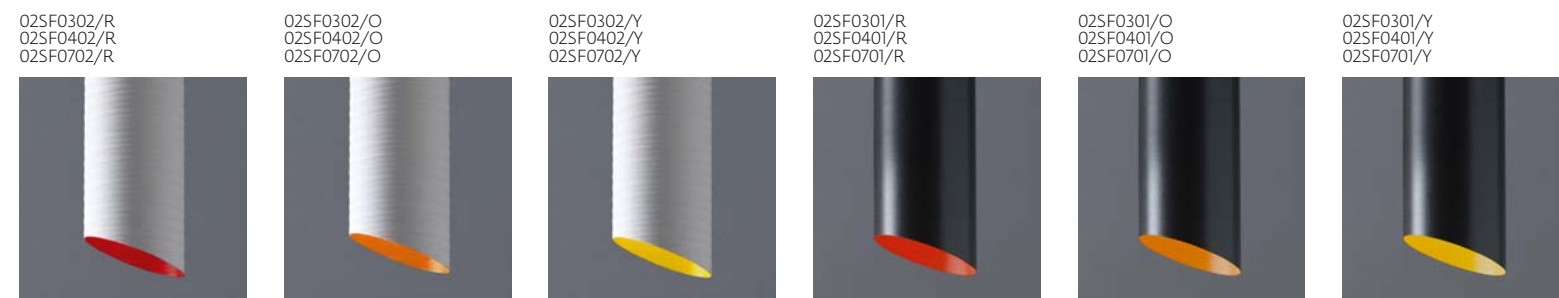
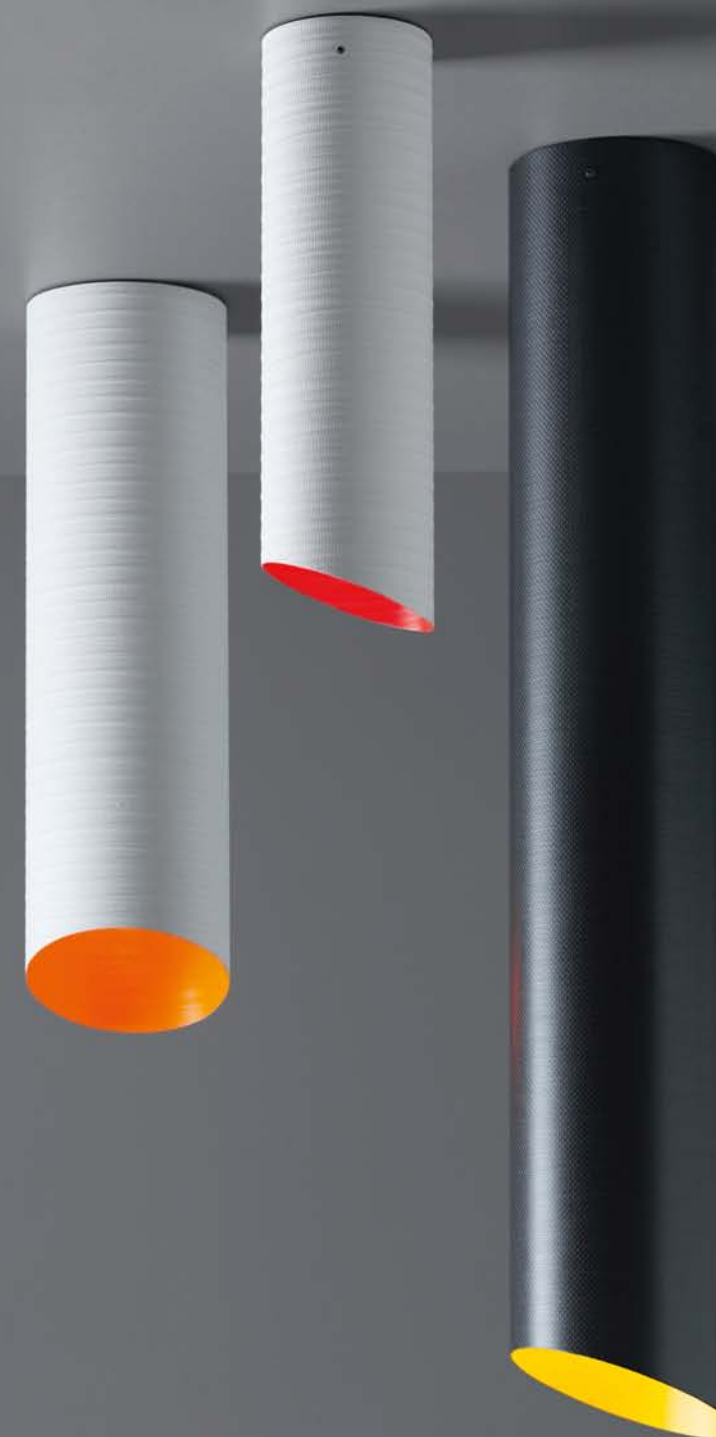



Lampada da tavolo realizzata in fibra di carbonio oppure in composito di fibra di vetro verniciato. Su richiesta disponibile in tutti i colori.

Table lamp in carbon fibre or in composite Fibreglass painted. On request, any color available.

Tischleuchte aus Kohlenstoff oder Glasfaser lackiert. Auf Wunsch in allen Farben lieferbar.

Lampe de table en fibre de carbone ou en fibre de verre laquées. Sur demande disponible dans toutes les couleurs.

02AP0302G
02AP0402G
02AP0702G

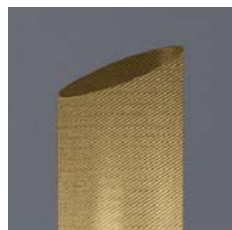

Special Gold Edition (G)

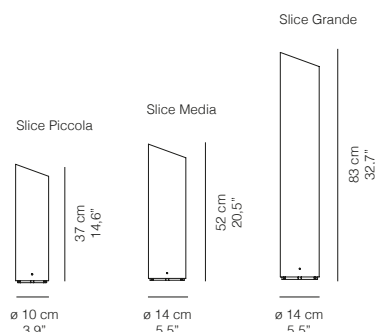

SLICE / Design Enrico Franzolini with Vicente Garcia Jimenez

Da appoggio/ Table desk

MISURE / DIMENSIONS

	CM.	INCHES
SLICE Piccola	10ø x 37H	3,9ø x 14,6H
SLICE Media	14ø x 52H	5,5ø x 20,5H
SLICE Grande	14ø x 83H	82ø x 32,7H

SORGENTI LUMINOSE / LIGHT SOURCES

HALOG.	LED	FLUO
max 1x75W E27 PAR 30S	1x11W 230V E27 PAR 30S	
max 1x100W E27 PAR 38	1x16W E27 PAR 38	1x23W E27 PAR 38
max 1x100W E27 PAR 38	1x16W E27 PAR 38	1x23W E27 PAR 38

SLICE Piccola

02AP0301+/Y/R/O
02AP0302+/Y/R/O
02AP0302G

COLORI / COLOURS

Fibra di carbonio / Carbon fibre - Interno giallo/yellow inside (Y) - Interno rosso / red inside (R) - Interno arancio / orange inside (O)
Fibra di vetro bianco / White Fibreglass - Interno giallo / yellow inside (Y) - Interno rosso / red inside (R) - Interno arancio / orange inside (O)
Fibra di vetro oro / Gold Fibreglass- Interno oro / Gold inside

SLICE Media

02AP0401+/Y/R/O
02AP0402+/Y/R/O
02AP0302G

COLORI / COLOURS

Fibra di carbonio / Carbon fibre - Interno giallo / yellow inside (Y) - Interno rosso / red inside (R) - Interno arancio / orange inside (O)
Fibra di vetro bianco / White Fibreglass - Interno giallo / yellow inside (Y) - Interno rosso / red inside (R) - Interno arancio / orange inside (O)
Fibra di vetro oro / Gold Fibreglass- Interno oro / Gold inside

SLICE Grande

02AP0701+/Y/R/O
02AP0702+/Y/R/O
02AP0702G

COLORI / COLOURS

Fibra di carbonio / Carbon fibre - Interno giallo / yellow inside (Y) - Interno rosso / red inside (R) - Interno arancio / orange inside (O)
Fibra di vetro bianco / White Fibreglass - Interno giallo / yellow inside (Y) - Interno rosso / red inside (R) - Interno arancio / orange inside (O)
Fibra di vetro oro / Gold Fibreglass - Interno oro / Gold inside

OPZIONI / OPTIONS

Dimmer

CERTIFICATIONS

CE IP 20

CERTIFICATIONS

CE IP 20

CERTIFICATIONS

CE IP 20

02AP0302/R
02AP0402/R
02AP0702/R



02AP0302/O
02AP0402/O
02AP0702/O



02AP0302/Y
02AP0402/Y
02AP0702/Y



02AP0301/R
02AP0401/R
02AP0701/R



02AP0301/O
02AP0401/O
02AP0701/O



02AP0301/Y
02AP0401/Y
02AP0701/Y



Slice Piccola / Media / Grande / Da appoggio / Table desk / Table / Standleuchte

Lampada da terra realizzata in fibra di carbonio oppure in composito di fibra di vetro verniciato. Su richiesta disponibile in tutti i colori.

Floor lamp in carbon fibre or in composite Fibreglass painted. On request, any color available.

Stehleuchte aus Kohlenstoff oder Glasfaser lackiert. Auf Wunsch in allen Farben lieferbar.

Lampadaire de table en fibre de carbone ou en fibre de verre laquées. Sur demande disponible dans toutes les couleurs.

SLICE Floor / Terra / Floor / Lampadaire / Stehleuchte

02TR1802G

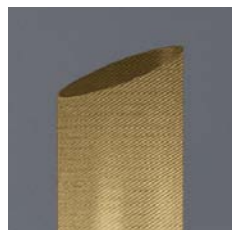

Special Gold Edition (G)



SLICE / Design Enrico Franzolini with Vicente Garcia Jimenez

SLICE Floor	Terra / Floor		SORGENTI LUMINOSE / LIGHT SOURCES			CERTIFICATIONS
	MISURE / DIMENSIONS					
	CM.	INCHES	HALOG.	LED	FLUO	
	14ø x 180H	5,5ø x 70,9H	max 1x100W E27 PAR 38	1x16W E27 PAR 38	1x23W E27 PAR 38	CE IP 20
	COLORI / COLOURS					
02TR1801+/Y/R/O	Fibra di carbonio / Carbon fibre - Interno giallo/yellow inside (Y) - Interno rosso / red inside (R) - Interno arancio / orange inside (O)					
02TR1802+/Y/R/O	Fibra di vetro bianco / White Fibreglass - Interno giallo / yellow inside (Y) - Interno rosso / red inside (R) - Interno arancio / orange inside (O)					
02TR1802G	Fibra di vetro oro / Gold Fibreglass - Interno oro / Gold inside					
	OPZIONI / OPTIONS					
DITR	Dimmer					

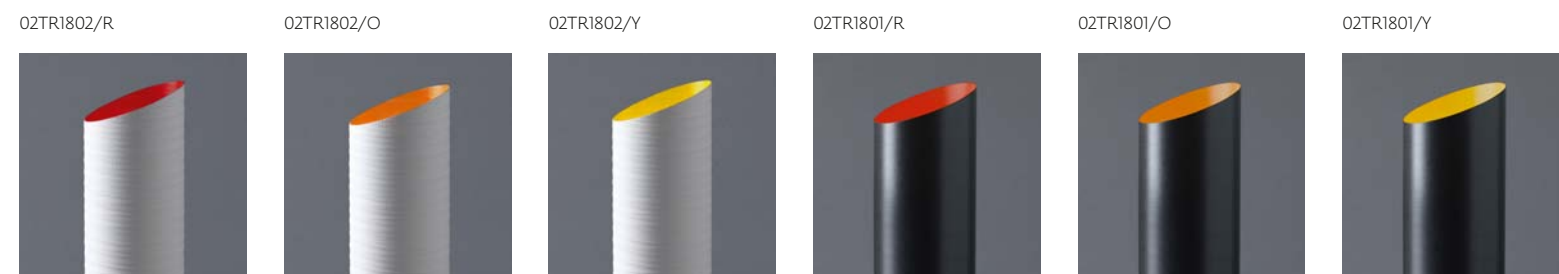

TUBE /

Design Enrico Franzolini with Vicente Garcia Jimenez

Collezione composta da lampade a sospensione, parete e soffitto, disponibili in diversi diametri e lunghezze. I cilindri sono realizzati in fibra di carbonio o in composito di fibra di vetro verniciata.

Collection made up of hanging, wall and ceiling lamps, available in various diameters and lengths. The cylinders are in carbon fibre or in painted composite fibreglass.

Suspension, plafonnier et applique créée en fibre de carbone ou en fibre de verre laquées. Sur demande disponible dans toutes les couleurs.

Kollektion TUBE bestehend aus Pendel-, Wand- und Deckenleuchten, in zahlreichen Maßen und Längen erhältlich. Zylindern aus Kohlenstoff oder aus Glasfaserstoff lackiert. Auf Wunsch in auch in anderen Ausführungen lieferbar.



Lampada a sospensione realizzata in fibra di carbonio oppure in composito di fibra di vetro verniciato. Su richiesta disponibile in tutti i colori.

Suspended lamp in carbon fibre or in composite Fibreglass painted. On request, any color available.

Pendelleuchte aus Kohlenstoff oder aus Glasfaserstoff lackiert. Auf Wunsch in allen Ausführungen lieferbar.

Suspension créée en fibre de carbone ou en fibre de verre laquées. Sur demande disponible dans toutes les couleurs.

01SP03007
01SP04007
01SP07007



Special Gold Edition (G)

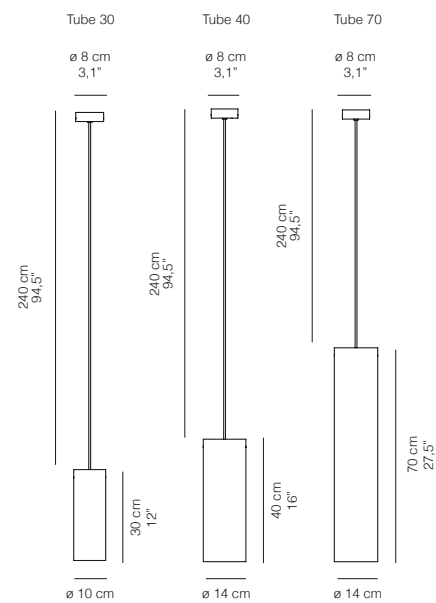

TUBE / Design Enrico Franzolini with Vicente Garcia Jimenez

Sospensione/ Suspended		SORGENTI LUMINOSE / LIGHT SOURCES		
MISURE / DIMENSIONS		HALOG.	LED	FLUO
CM.	INCHES			
TUBE 30	10ø x 30-240H	3,9ø x 12-94,5H	max 1x75W E27 PAR 30S	1x11W 230V E27 PAR 30S
TUBE 40	14ø x 40-240H	5,5ø x 16-94,5H	max 1x100W E27 PAR 38	1x16W E27 PAR 38 1x23W E27 PAR 38
TUBE 70	14ø x 70-240H	5,5ø x 27,5-94,5H	max 1x100W E27 PAR 38	1x16W E27 PAR 38 1x23W E27 PAR 38
TUBE 30		COLORI / COLOURS		
01SP03001		Fibra di carbonio / Carbon fibre		
01SP0300+2/3/5/6		Fibra di vetro / Fibreglass:: Bianco / White (2) - Rosso / Red (3) - Arancio / Orange (5) - Argento / Silver (6)		
01SP03007		Fibra di vetro oro / Gold Fibreglass - Interno oro / Gold inside		
TUBE 40		COLORI / COLOURS		
01SP04001		Fibra di carbonio / Carbon fibre		
01SP0400+2/3/5/6		Fibra di vetro / Fibreglass:: Bianco / White (2) - Rosso / Red (3) - Arancio / Orange (5) - Argento / Silver (6)		
01SP04007		Fibra di vetro oro / Gold Fibreglass - Interno oro / Gold inside		
TUBE 70		COLORI / COLOURS		
01SP07001		Fibra di carbonio / Carbon fibre		
01SP0700+2/3/5/6		Fibra di vetro / Fibreglass:: Bianco / White (2) - Rosso / Red (3) - Arancio / Orange (5) - Argento / Silver (6)		
01SP07007		Fibra di vetro oro / Gold Fibreglass - Interno oro / Gold inside		
OPZIONI / OPTIONS		CERTIFICATIONS		
SMT		Sospensione cablaggio lunghezza cavi mt. 5,00 / Suspended with longer cables mt. 5,00		
		CERTIFICATIONS		
		☐ ▽ CE IP 20		
		CERTIFICATIONS		
		☐ ▽ CE IP 20		
		CERTIFICATIONS		
		☐ ▽ CE IP 20		

01SP03002
01SP04002
01SP07002



01SP03003
01SP04003
01SP07003



01SP03005
01SP04005
01SP07005



01SP03006
01SP04006
01SP07006



01SP03001
01SP04001
01SP07001



Tube 30-40-70 / Sospensione / Suspended / Suspension / Pendelleuchte

Lampada da soffitto realizzata in fibra di carbonio oppure in composito di fibra di vetro verniciato. Su richiesta disponibile in tutti i colori.

Ceiling lamp in carbon fibre or in composite Fibreglass painted. On request, any color available.

Deckenleuchten aus Kohlenstoff oder aus Glasfaserstoff lackiert. Auf Wunsch in allen Ausführungen lieferbar.

Plafonnier créée en fibre de carbone ou en fibre de verre laquées. Sur demande disponible dans toutes les couleurs.

Tube 30-40-70 / Soffitto / Ceiling / Plafonnier / Deckenleuchte

01SF03007
01SF04007
01SF07007



Special Gold Edition (G)

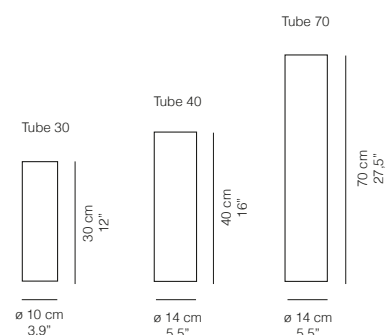

TUBE / Design Enrico Franzolini with Vicente Garcia Jimenez

Soffitto/ Ceiling		SORGENTI LUMINOSE / LIGHT SOURCES			
MISURE / DIMENSIONS		HALOG.	LED	FLUOR	
CM.	INCHES				
TUBE 30	10ø x 30H	3,9ø x 12H	max 1x75W E27 PAR 30S	1x11W 230V E27 PAR 30S	
TUBE 40	14ø x 40H	5,5ø x 16H	max 1x100W E27 PAR 38	1x16W E27 PAR 38	1x23W E27 PAR 38
TUBE 70	14ø x 70H	5,5ø x 27,5H	max 1x100W E27 PAR 38	1x16W E27 PAR 38	1x23W E27 PAR 38
COLORI / COLOURS		CERTIFICATIONS			
TUBE 30	Fibra di carbonio / Carbon fibre	☐ ▽ CE IP 20			
01SF03001	Fibra di vetro / Fibreglass:: Bianco / White (2) - Rosso / Red (3) - Arancio / Orange (5) - Argento / Silver (6)	☐ ▽ CE IP 20			
01SF0300+2/3/5/6	Fibra di vetro oro / Gold Fibreglass - Interno oro / Gold inside	☐ ▽ CE IP 20			
01SF03007					
TUBE 40	Fibra di carbonio / Carbon fibre	☐ ▽ CE IP 20			
01SF04001	Fibra di vetro / Fibreglass:: Bianco / White (2) - Rosso / Red (3) - Arancio / Orange (5) - Argento / Silver (6)	☐ ▽ CE IP 20			
01SF0400+2/3/5/6	Fibra di vetro oro / Gold Fibreglass - Interno oro / Gold inside	☐ ▽ CE IP 20			
01SF03007					
TUBE 70	Fibra di carbonio / Carbon fibre	☐ ▽ CE IP 20			
01SF07001	Fibra di vetro / Fibreglass:: Bianco / White (2) - Rosso / Red (3) - Arancio / Orange (5) - Argento / Silver (6)	☐ ▽ CE IP 20			
01SF0700+2/3/5/6	Fibra di vetro oro / Gold Fibreglass - Interno oro / Gold inside	☐ ▽ CE IP 20			
01SF07007					

01SF03002
01SF04002
01SF07002



01SF03003
01SF04003
01SF07003

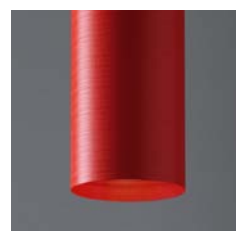

01SF03005
01SF04005
01SF07005



01SF03006
01SF04006
01SF07006



01SF03001
01SF04001
01SF07001



Lampada da parete realizzata in fibra di carbonio oppure in composito di fibra di vetro verniciato. A doppia emissione, diretta ed indiretta. Su richiesta disponibile in tutti i colori.

Wall-mounted lamp in carbon fibre or in composite Fibreglass painted. With direct/Indirect light emission. On request, any color available.

Wandleuchte aus Kohlenstoff oder lackierter Glasfaser. Direkte und indirekte Beleuchtung. Auf Wunsch in allen Farben lieferbar.

Applique créée en fibre de carbone ou en fibre de verre laquées. Émission de la lumière directe/indirecte. Sur demande disponible dans toutes les couleurs.

Tube / Parete / Wall-mounted / Applique / Wandleuchte

01PA04007



Special Gold Edition (G)

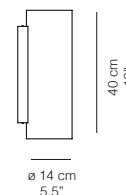

TUBE / Design Enrico Franzolini with Vicente Garcia Jimenez

TUBE	Parete / Wall	SORGENTI LUMINOSE / LIGHT SOURCES			CERTIFICATIONS
	MISURE / DIMENSIONS				
	CM. INCHES	HALOG.	LED	FLUO	
	14ø x 40H 5,5ø x 16H	max 2x100W E27 PAR 38	2x16W E27 PAR 38	2x23W E27 PAR 38	CE IP 20
	COLORI / COLOURS				
01PA04001	Fibra di carbonio / Carbon fibre				
01PA0400+2/3/5/6	Fibra di vetro / Fibreglass:: Bianco / White (2) - Rosso / Red (3) - Arancio / Orange (5) - Argento / Silver (6)				
01PA04007	Fibra di vetro oro / Gold fibreglass - Interno oro / Gold inside				

01PA04002



01PA04003



01PA04005



01PA04006



01PA04001



Graphics:
Portfolio.is.it
Beeld.it

Photo:
Ikon
Beeld.it

Color separation:
Luce Group
Beeld.it

Thanks to:
Enrico Franzolini
Acheo Srl p. 205
Luciano Franz Gioielleria pp. 213, 216
Arch. Curzio Pentimalli - Private house Treviso
pp.11, 12, 15, 18, 23, 33, 157, 231, 235
Jesse Spa pp. 37, 38, 45, 46, 51, 23, 101, 102, 139,
142, 161, 169, 190, 196
Mastella Design p. 162

Dovuto alla nostra politica di continuo miglioramento, ci riserviamo il diritto di apportare delle modifiche a dettagli e specifiche in qualsiasi momento.

Lampadine su richiesta.

We reserve the right to change details and specifications at any time due to our policy of continuous improvement.

Bulbs upon request.

Suivant notre politique d'amélioration continue, nous nous réservons le droit d'apporter en tout moment des modifications aux détails et spécifications.

Ampoules sur requête.

Aufgrund unserer Politik der ständigen Verbesserung, behalten wir uns das Recht vor, Details und Spezifikationen an unseren Produkten ohne vorherige Anmeldung ändern zu dürfen.

Leuchtmittel auf Anfrage.

karboxx srl
Via Cornarè, 12
Basalghelle
31040 Mansuè
(Treviso) Italy
www.karboxx.com

karboxx